



Ai120 180 Upgrade – OPERATORS MANUAL

© PLB Australasia Pty Ltd as trustee for PLB Trust trading as Liquid Systems (SA)

Version 1.0



TABLE OF CONTENTS

1. IMPORTANT INFORMATION

ABOUT THIS MANUAL.....	1.1
PRODUCT IDENTIFICATION	1.1
WARRANTY	1.1
SAFETY AND DAMAGE WARNINGS.....	1.1
IMPORTANT SAFETY INSTRUCTIONS	1.2

2. SPECIFICATIONS

ABOUT THE SYSTEM	2.1
SYSTEM COMPONENTS.....	2.1
Module	2.1
Tank Plumbing Kit	2.2
HYDRAULIC REQUIREMENTS	2.3
ELECTRICAL REQUIREMENTS	2.3
MODULE COMPONENTS	2.4
SYSTEM LAYOUT.....	2.6

3. INSTALLATION

MOUNT MODULE.....	3.1
INSTALL TANK PLUMBING.....	3.1
Suction Lines	3.1
Servo Bypass Return Line	3.2
Product Tank PRV Return Line	3.3
Purge Line	3.4
Metered Output (Umbilical) Line.....	3.5
Tank Agitation Kit	3.6
CONNECT HYDRAULICS	3.7
CONNECT ELECTRONICS.....	3.7

4. PRE-OPERATIONAL CALIBRATION & TESTING

CHECK AND ADJUST PUMP SPEED	4.1
CONTROLLER CONFIGURATION.....	4.2
CHECK DISTRIBUTION SYSTEM OUTLETS	4.2
GREENSTAR RATE CONTROLLER CONFIGURATION	4.2
FLOW METER CALIBRATION	4.3
OPERATIONAL TESTING.....	4.3

5. OPERATION

STARTUP	5.1
MONITORING	5.1
FLUSH SYSTEM (STATIC)	5.2
SHUTDOWN.....	5.3

6. MAINTENANCE

FLUSH SYSTEM	6.1
CHECK & CLEAN SUCTION FILTER	6.1
CHECK PUMP OIL LEVEL	6.1
FLUSH DISTRIBUTION SYSTEM - MANUAL	6.2

7. TROUBLESHOOTING

.....	7.1
-------	-----

8. REPLACEMENT PARTS

.....	8.1
-------	-----

9. APPENDIX A - SECTION CONTROL

INSTALLATION	9.1
--------------------	-----

ABOUT THIS MANUAL

This manual includes instructions for installation, operation, maintenance and troubleshooting of the Liquid Systems (SA) Ai120 180 Upgrade Pump and Control Module.

All dimensions shown in this manual are in millimetres.

PRODUCT IDENTIFICATION

To enable identification of your product for parts, service and support, each Liquid Systems (SA) module has a model no. and serial no. inscribed on a plaque on the side of the module.

For quick reference, we suggest writing your model no. and serial no. in the spaces below.

Model No. _____

Serial No. _____

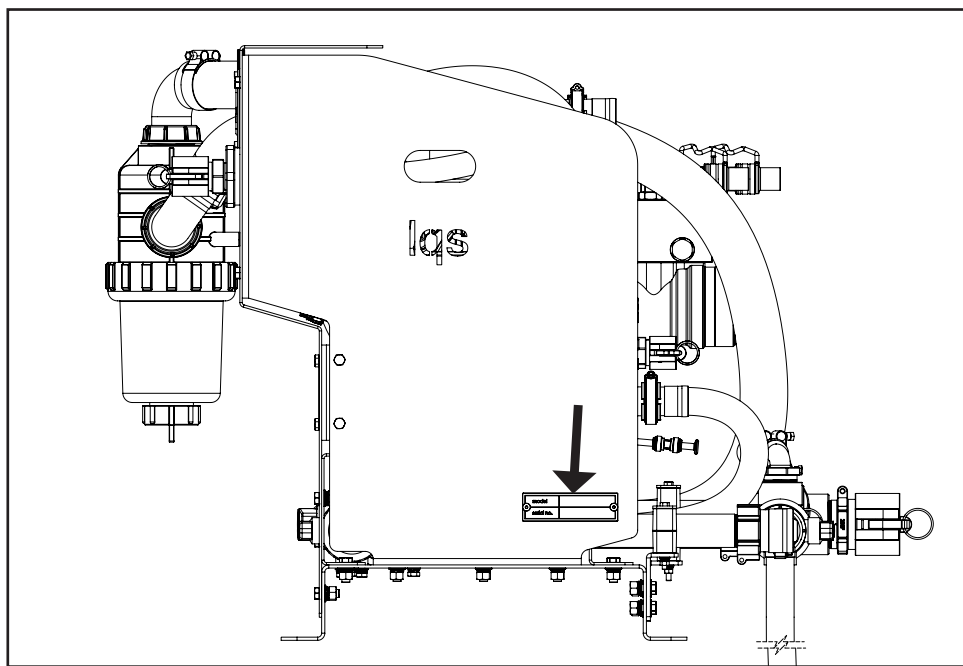

WARRANTY

Liquids Systems (SA) provides a 12 month Warranty from the date of installation provided that a Warranty Registration Form has been returned to Liquid Systems (SA) within 30 days of installation.

SAFETY AND DAMAGE WARNINGS

The terms WARNING, CAUTION and NOTE are used throughout this manual to stress the importance of personal safety, potential machinery damage and useful operating information.

Term description and usage is shown below.

⚠ WARNING: Indicates the strong possibility of severe personal injury or damage to machinery if instructions are not followed.

⚠ CAUTION: Highlights hazards, unsafe or unwise practices which could cause personal injury, property damage, damage to your machinery or loss of potential crop yield if instructions are not followed.

👉 NOTE: Refers to important and useful information which should not be overlooked.

⚠ WARNING:

Always wear protective gloves, eyewear and clothing when dealing with liquid fertilizers and other liquid agricultural products.

Do not disconnect any hose lines while the pump is running.

Ensure power is switched off or disconnected when connecting or disconnecting any electrical components of the system.

Always ensure the tank lid or a vent/overflow valve is open to allow air to escape when filling product tank.

⚠ WARNING:

Use of phosphoric acid with this equipment will void the warranty.

ABOUT THE SYSTEM

The Ai120 180 Upgrade Pump and Control Module has been designed to provide accurate and flexible rate controlled application of clear liquid fertilizers and other high analysis agricultural liquids.

Currently supported electronic control systems include:

- John Deere Greenstar™ displays with Greenstar Rate Controller or Rate Controller 2000
- Ag Leader Versa, Integra and InCommand 800 or 1200 displays
- Topcon Eagle 15, X20, X30 and X35 displays via MDECU or Apollo ECU
- Trimble FmX, CFX-750 and TMX-2050 and GFX-750 displays via Field IQ module
- Dickey John IntelliAg ISOBUS controllers
- Liquid Systems (SA) L2 dual liquid controller

Options are also available for ISOBUS VT capable displays. Contact Liquid Systems (SA) for advice on integration with other brands of controller.

This manual provides instructions for integration with Greenstar™ Rate Controllers and display.

SYSTEM COMPONENTS

Module

Cabinet material 4 mm (base and stand), 3 mm (cabinet). All made from 304 stainless steel

Weight 108 kg

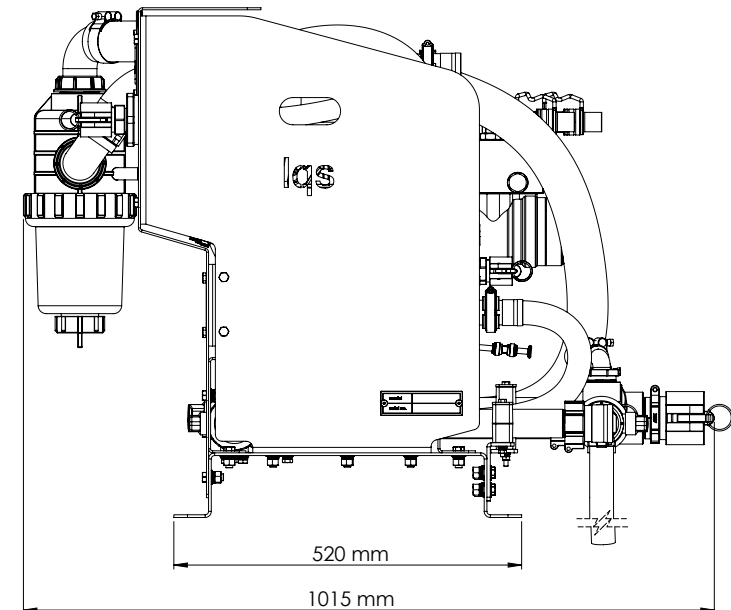
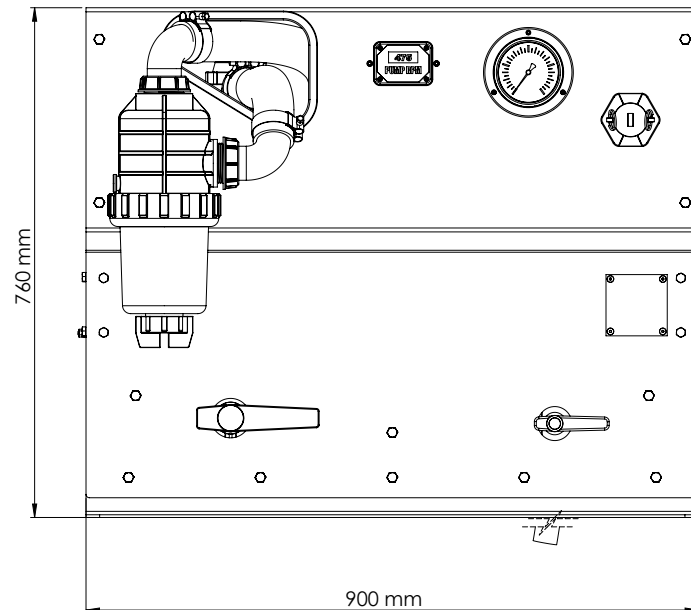

Tank Plumbing Kit

The tank plumbing kit provides all tank fittings, components and lines for connecting the module to product and flush tanks and the downstream distribution system.

Suction Lines X 2



Servo Bypass Line



PRV Dump Line



Purge Line



Umbilical Line



Agitation Kit



HYDRAULIC REQUIREMENTS

The Bertolini 2180 pump in this system is driven by a speed protected hydraulic motor. The hydraulic requirements are specified below:

Displacement per Revolution	50cc
Max Operating Speed	550 rpm
Max Hydraulic Pressure	1500 psi
Max Hydraulic Flowrate	30 L/min, 7.9 US Ga/min, 6.6 Imp. Ga/min

Male hydraulic quick releases are provided for connecting hydraulic lines to the module.

ELECTRICAL REQUIREMENTS

The Ai120 180 Upgrade Pump and Control Module requires 12V electrical power for the Auto-Rate Control Valve Set and digital Pump Speed readout. The module draws power through its connection to the electronic control system installed on the tractor.

Nominal Voltage	12V
Maximum Current	1.3A



MODULE COMPONENTS

FRONT VIEW

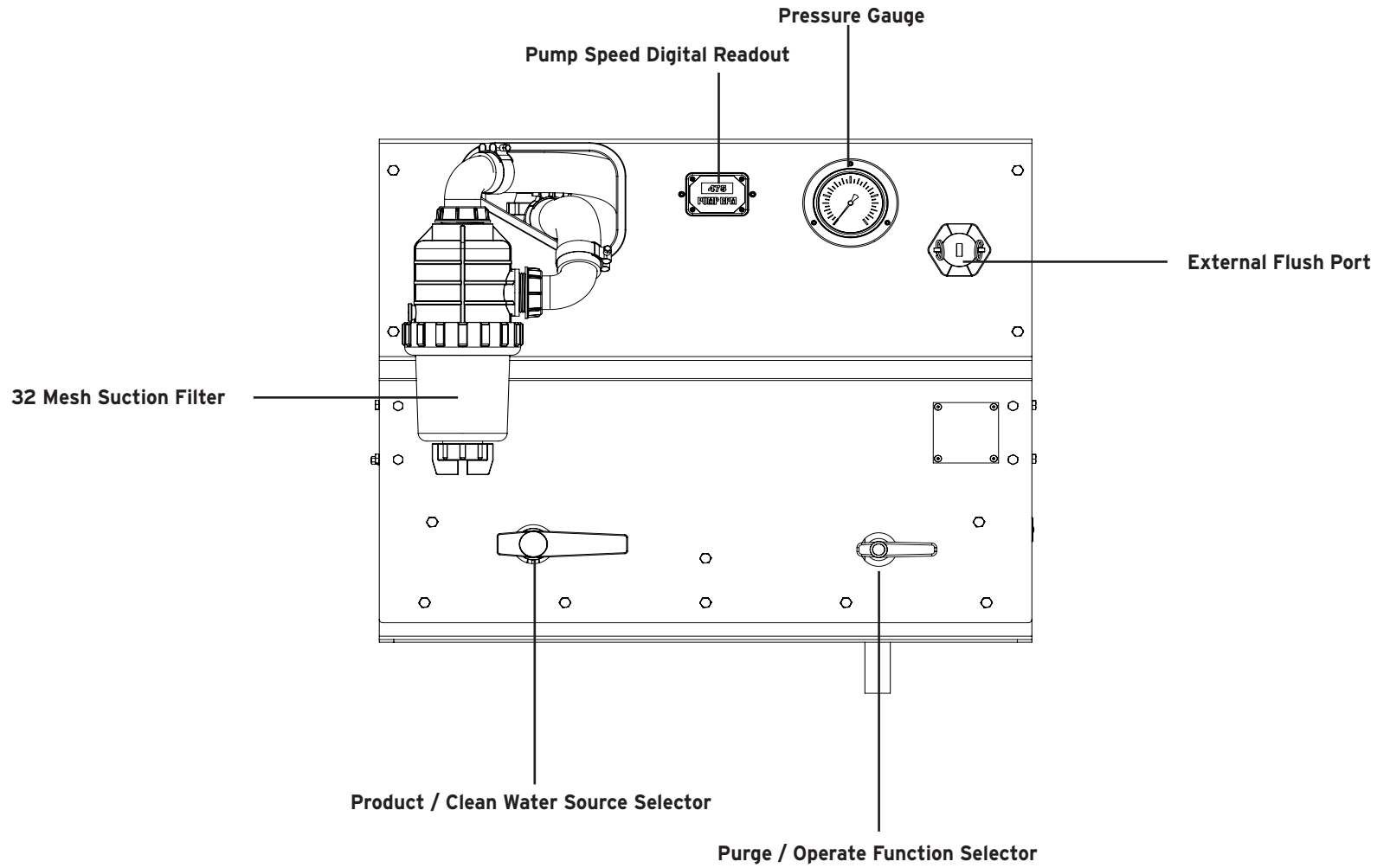

BACK VIEW

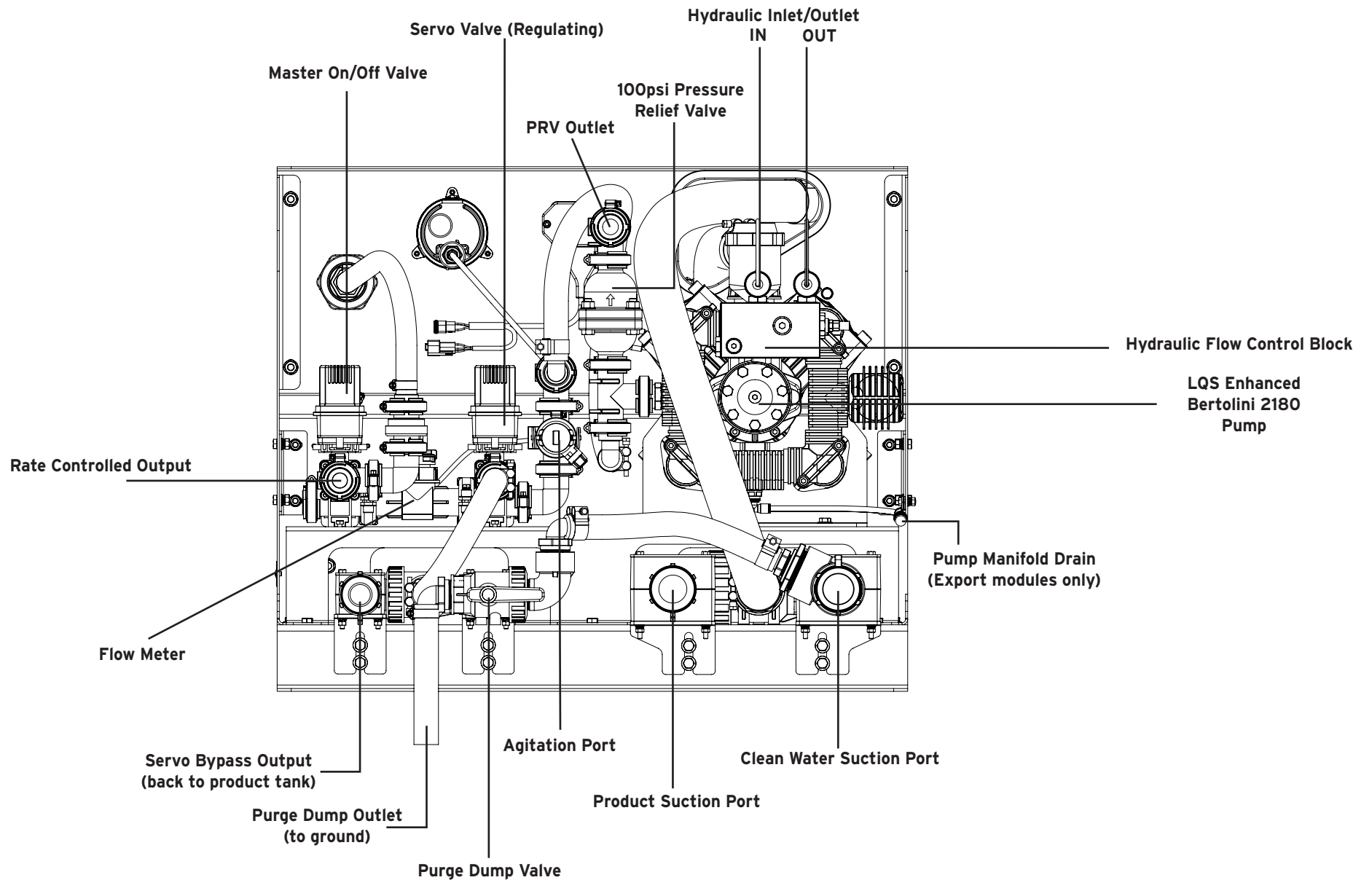

Ai120 180 Upgrade SYSTEM LAYOUT

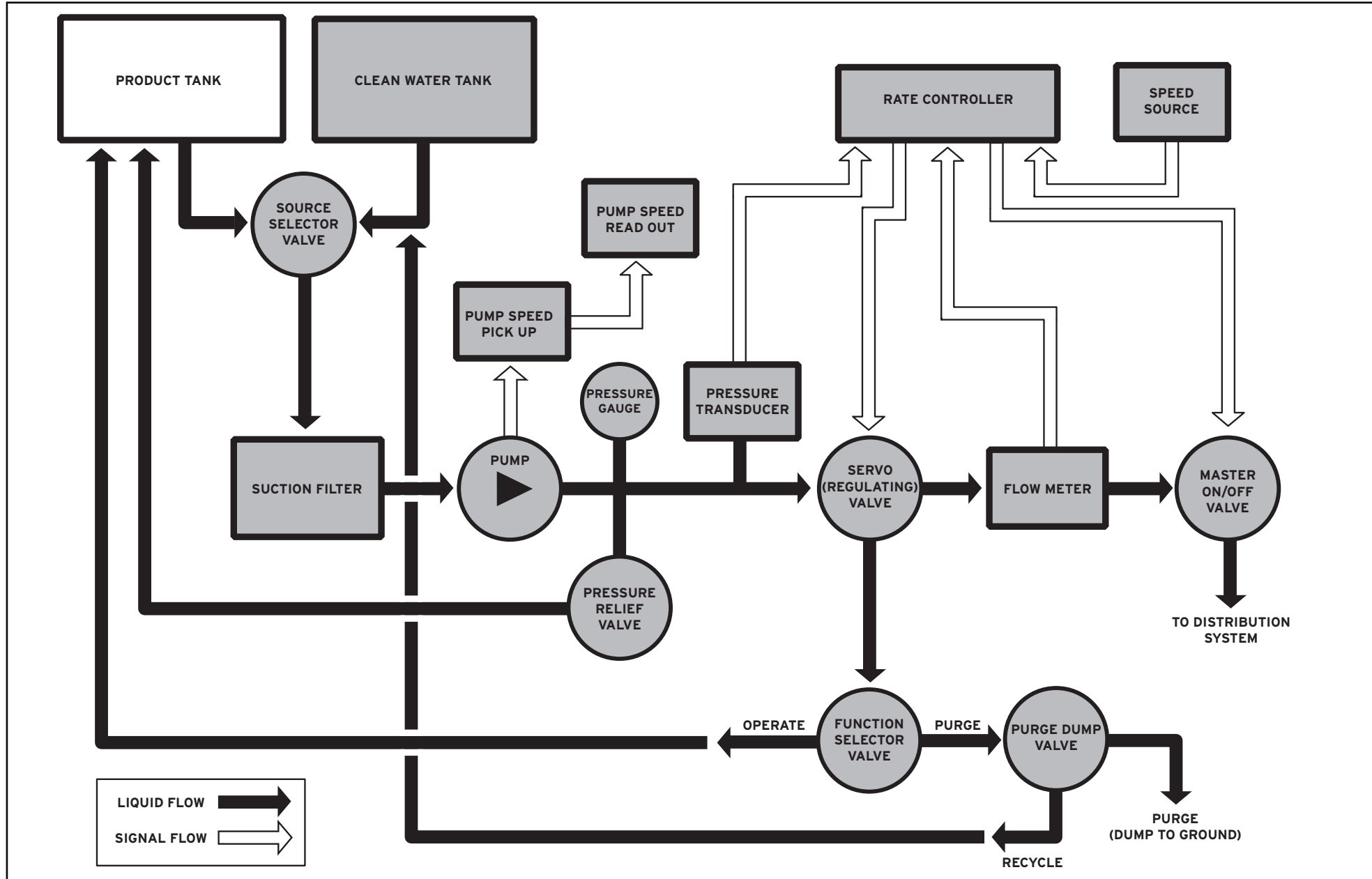

MOUNT MODULE

The Ai120 180 Upgrade module needs to be mounted on an existing implement such as an air seeder cart or dedicated liquid cart. The most suitable location for mounting the module will depend on the configuration of implements being used.

Factors to consider when selecting a mounting location.

- Ensure the mounting of the module does not interfere with functionality of implement. E.g. Steering, Augers, fans.
- Lengths of hydraulic hose required to connect to the module.
- Location of electronic control units/modules and routing distances of wiring harnesses. (Liquid Systems can provide extension harnesses if required.) from product and fresh water tanks for suction and return lines.
- Routing of suction and return lines.

Ensure hardware used for mounting will support the weight of the module. Slots for fasteners exist in the base of the module for attaching to support beams.

INSTALL TANK PLUMPING

Suction Lines x 2

Hose fittings for 2 suction lines are included for connecting the module to product and clean water tanks.

1. Cut 76mm diameter hole in sump or base of tank. It must be on a flat surface and requires 15mm clearance around the hole internally and 25mm externally.
2. Install tank outlet assembly and Cut 50mm suction hose to suitable length for routing from tank to module.
3. Attach suction line to appropriate suction port on rear of module.

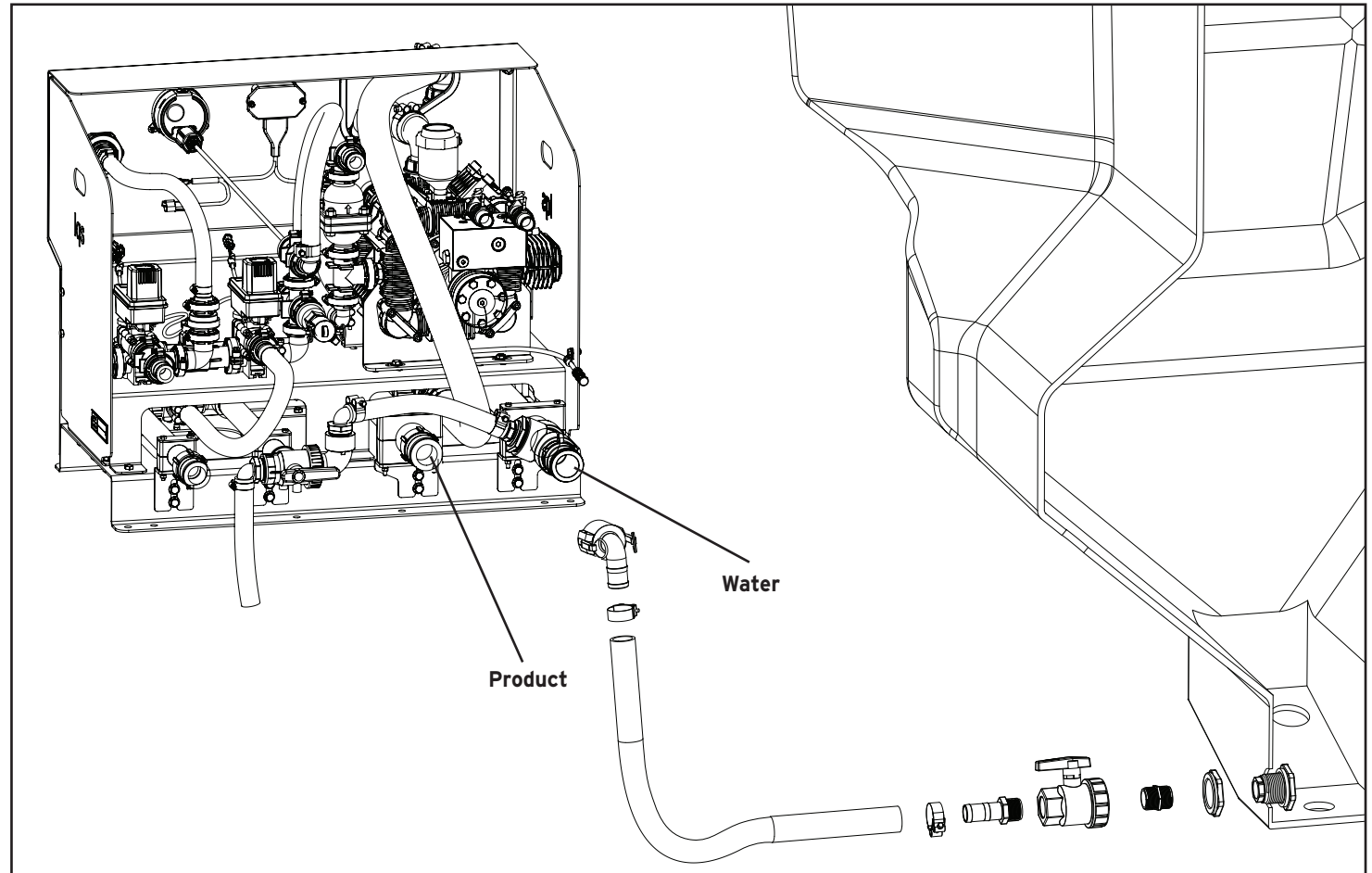

Servo Bypass Return Line

1. Cut 57mm diameter hole in tank. It must be on a flat surface and requires 13mm clearance around the hole internally and 20mm externally.
2. Install tank fitting and assemble Servo bypass return line as shown. Cut 25mm pressure hose to a suitable length for routing from tank to module.
3. Attach line to servo bypass outlet on rear of module

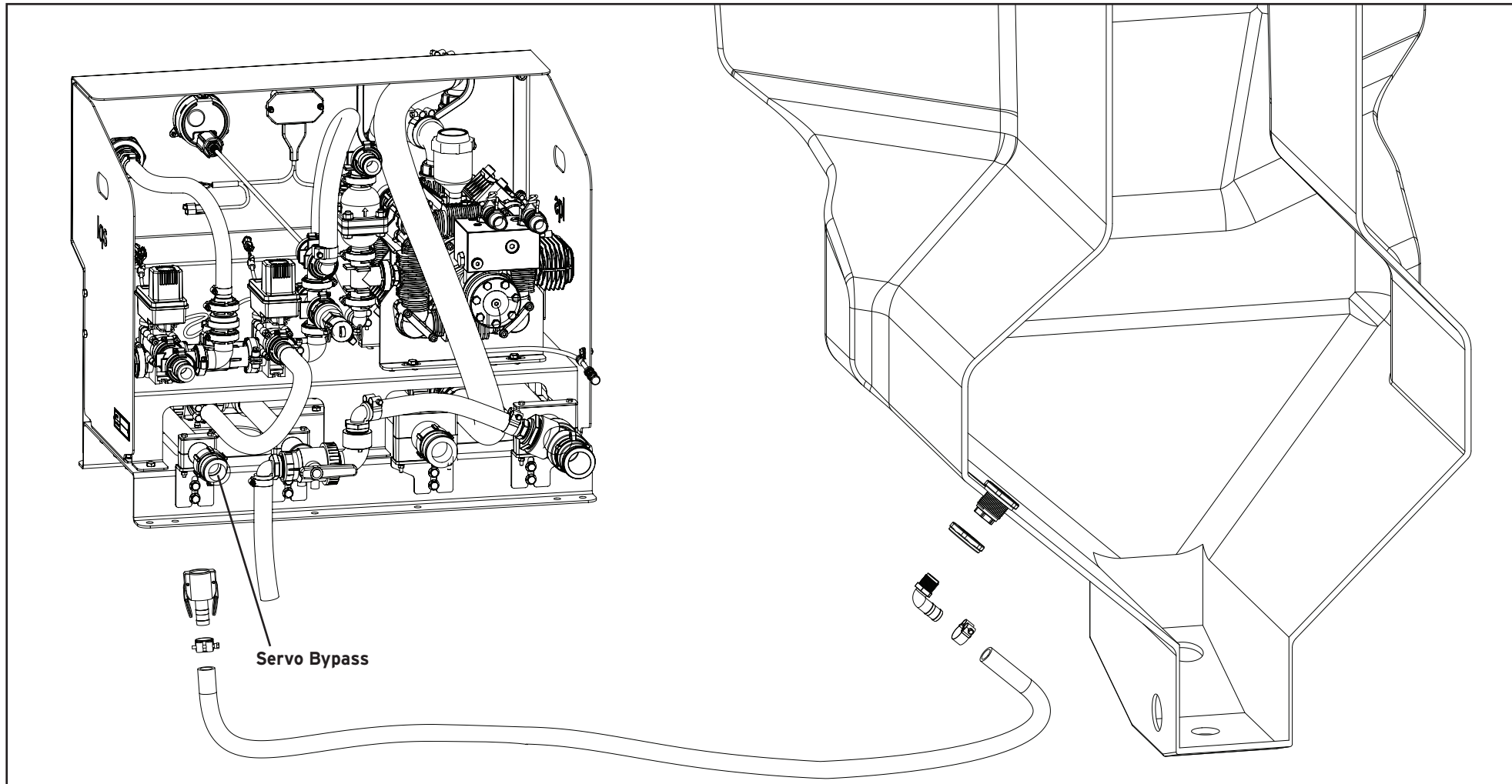

Product Tank PRV Return Line

1. Cut 57mm diameter hole in tank. It must be on a flat surface and requires 13mm clearance around the hole internally and 20mm externally.
2. Install tank fitting and assemble PRV return line as shown. Cut 25mm pressure hose to suitable length for routing from tank to module.
3. Attach line to PRV outlet on top of pressure relief valve.

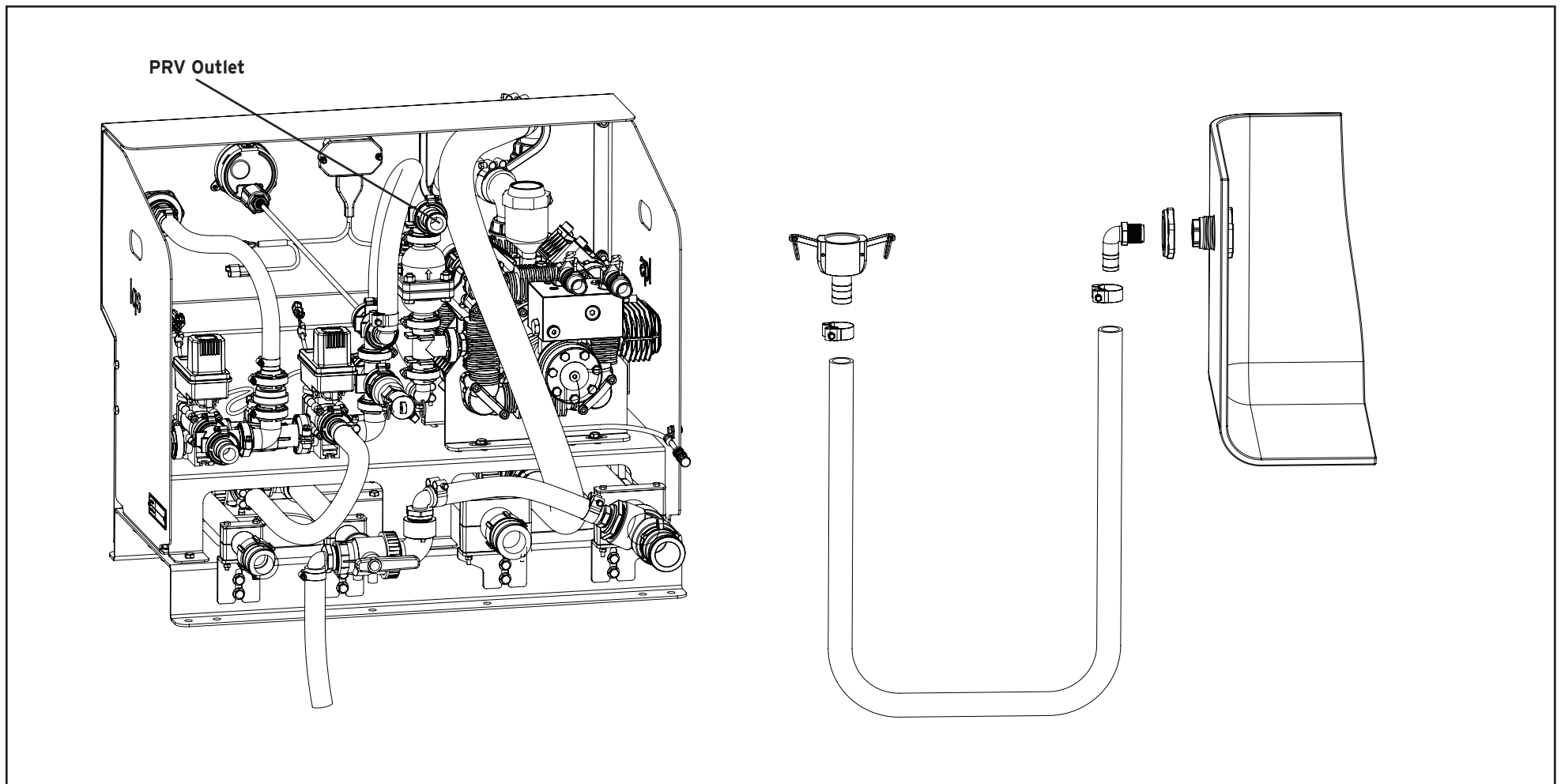

Purge Line

1. Assemble and attach Purge line as shown.

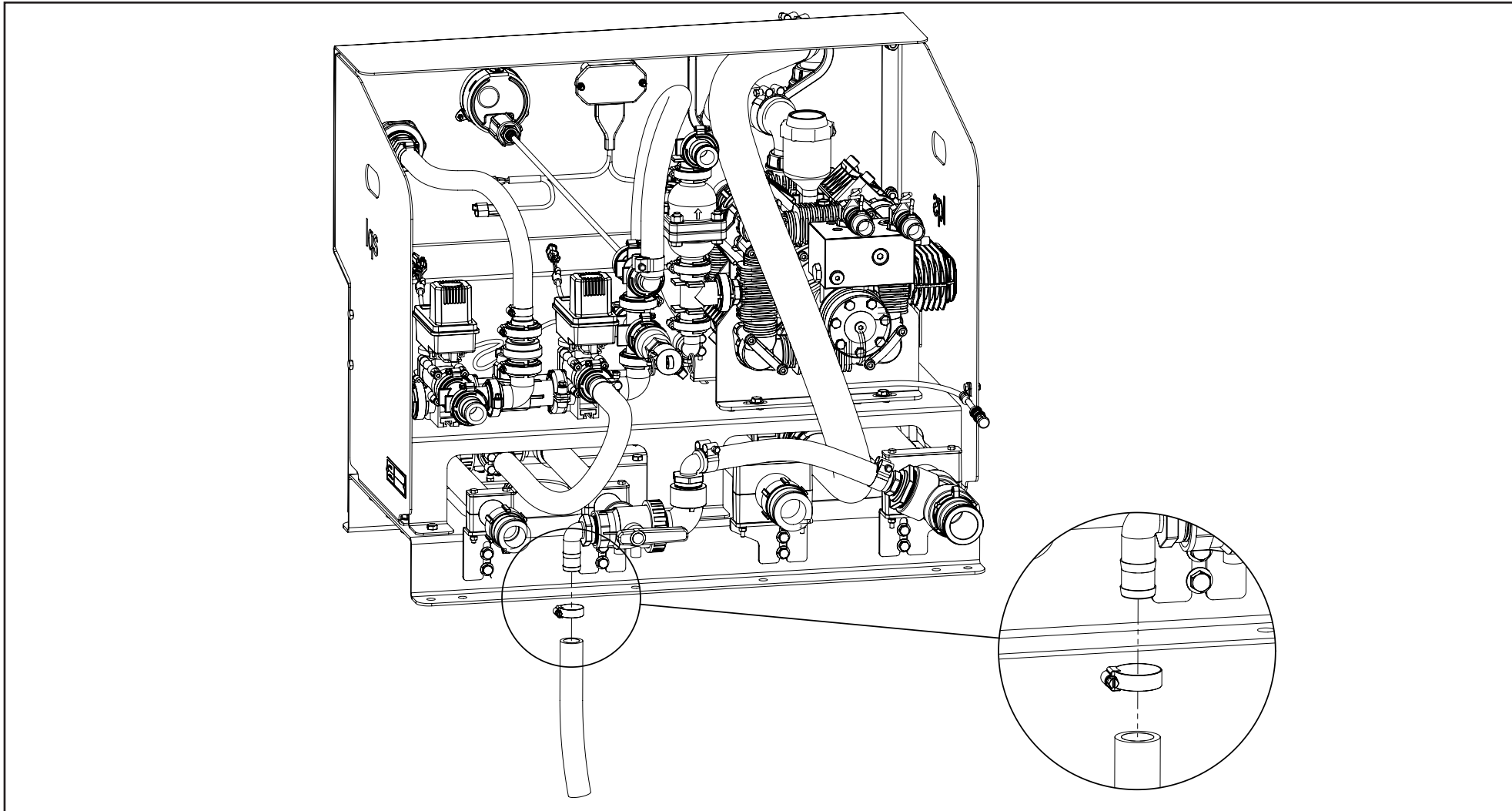

Metered Output (Umbilical) Line

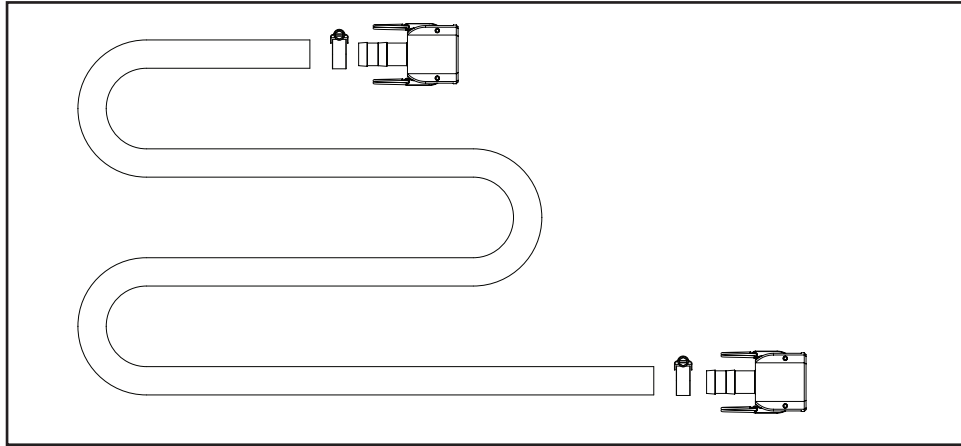

1. Assemble Umbilical Line as shown.

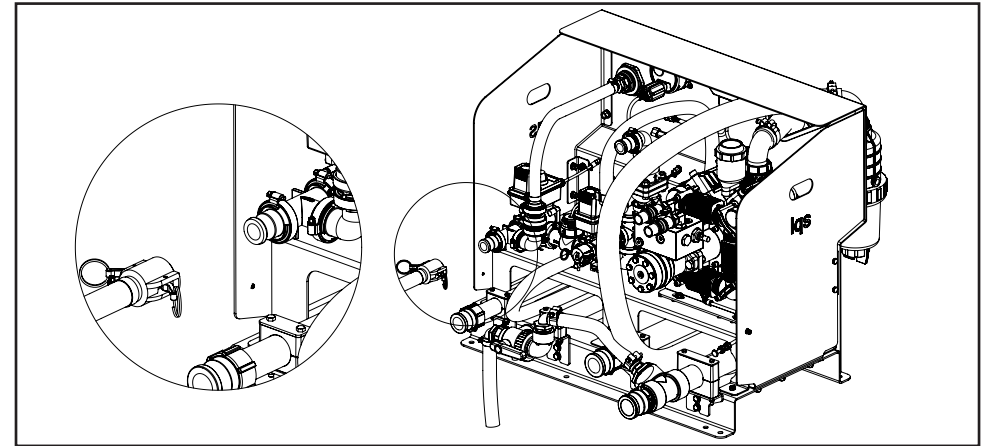

2. Connect umbilical line to metered output port on rear of Ai120 180 Upgrade module.

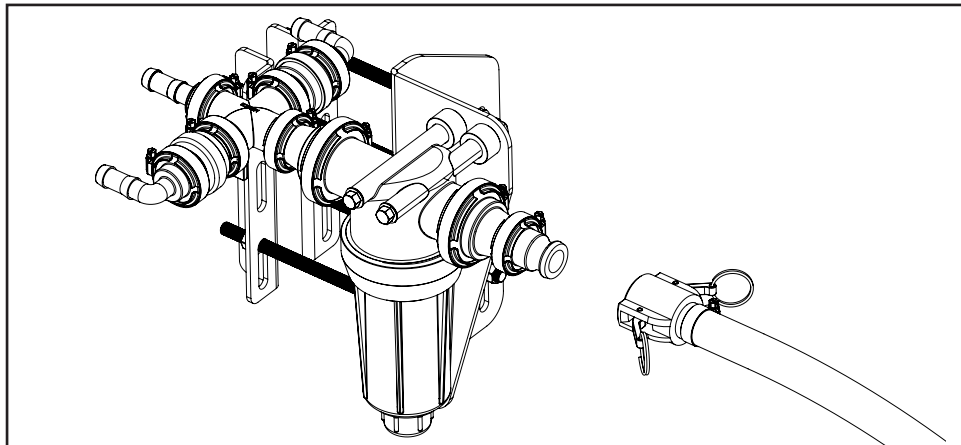

3. Connect umbilical line to Stacker Distribution System mounted on bar.
(Mounting bracket may differ from image shown.)

Tank Agitation Kit

If tank agitation is required, install the tank agitation kit as follows.

1. Select a mounting location for the agitator in the tank. The location should be close to the bottom of the tank.
2. Cut a 44mm diameter hole in the tank at the selected location. It must be on a flat surface and requires 13mm clearance around the hole internally and 20mm externally.
3. Assemble and install tank agitation kit as shown in diagram. Agitator should point towards the bottom of the tank.
4. Connect agitation line to agitation port on rear of module.

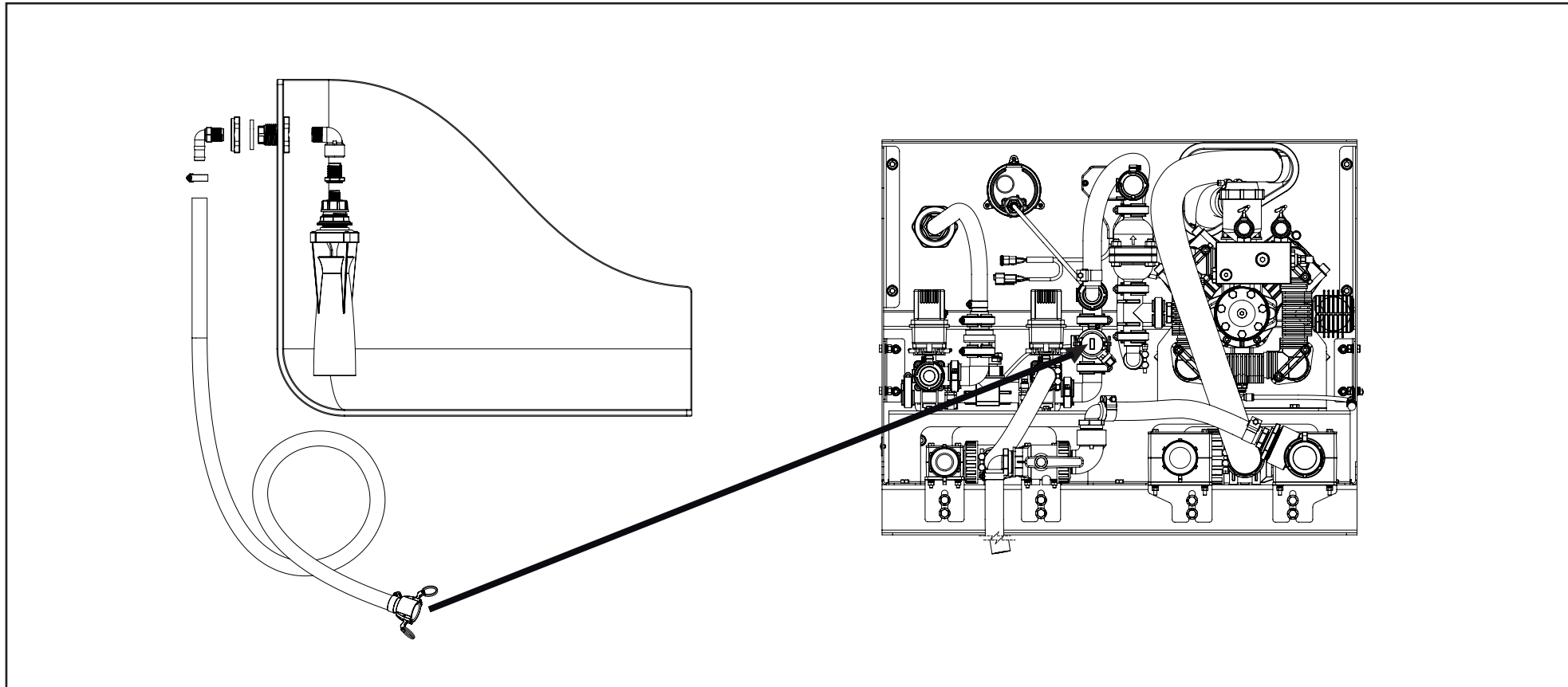

CONNECT HYDRAULICS

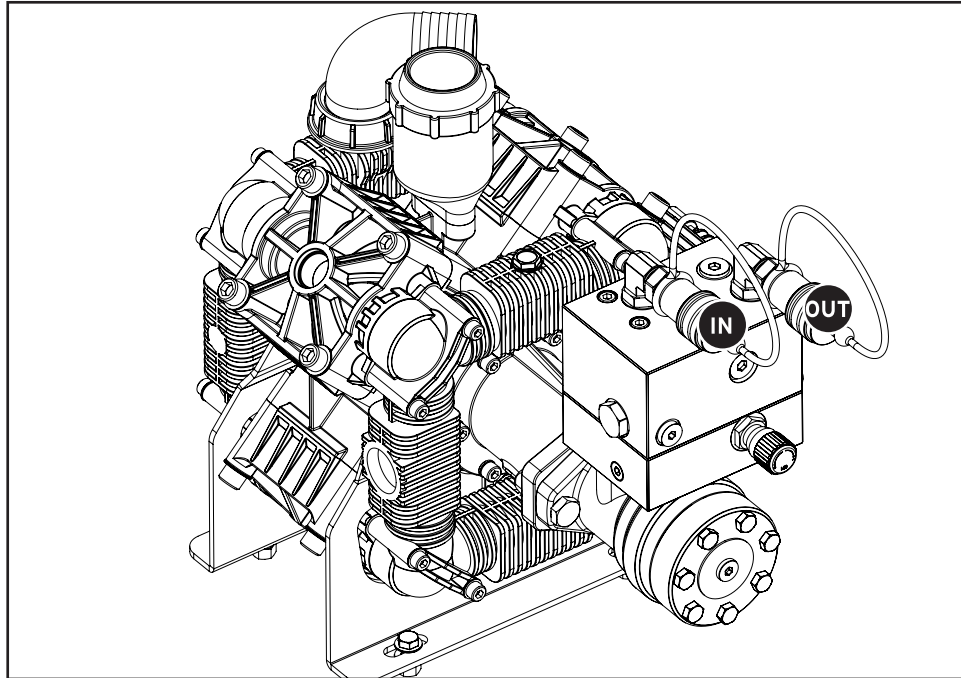

Connect hydraulic lines to hydraulic couplings on hydraulic flow control block. Male hydraulic quick releases are provided for this purpose.

NOTE: - Hydraulic inlet is marked with a P and outlet is marked with a T on the flow control block.
 - Ensure hydraulic input and output lines are fitted to the correct couplings otherwise pump will not run.

WARNING: Do not connect Ai120 hydraulics in series with any other equipment unless specifically instructed to by Liquid Systems (SA).

CONNECT ELECTRONICS

Refer to manufacturer's documentation for installation of precision ag displays and electronic control units or rate control modules.

1. For each valve set, connect the rate control system via the Liquid Systems supplied adaptor harness to flow meter, master on-off valve, regulating valve and pressure transducer with the matching connectors.

For control systems that can monitor pump speed, leave pump speed transducer connected to digital pump speed readout until after pump speed has been checked and adjusted at the next step.

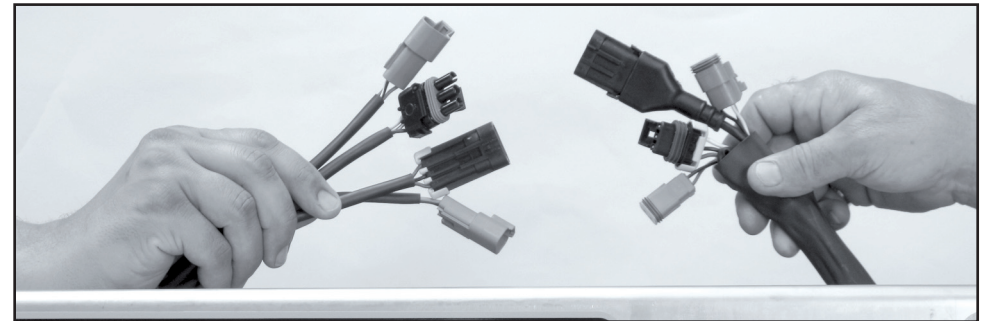

WARNING: Ensure electrical power is disconnected from the Rate Controller before connecting the adaptor harness.

CHECK AND ADJUST PUMP SPEED

The module has been wet-tested at the factory. Pump speed has been pre-set via the hydraulic flow control block to 420 RPM as part of the test procedure.

Due to differences in hydraulic sources, in some cases, the pump speed after installation may be different to the factory setting. In rare cases, the hydraulic flow may be temporarily blocked.

Use the following procedure to check and adjust the pump speed.

1. Ensure a source tank is selected which contains either water or liquid product.
2. Apply hydraulic power to the pump.
3. Check pump speed on the digital pump speed readout on the front of the module.
4. If the pump speed is outside of the specified range of 300 to 550 RPM then:
5. Remove protective screw cap (1/2") from the flow control cartridge.
6. Loosen locking nut (9/16")
7. Use an Allen key (3/16") to turn the adjusting screw – **anti-clockwise** to **increase** the speed.
8. Set pump speed between 300 and 550 RPM (check speed on digital readout).
If the hydraulic oil has not reached its usual operating temperature, do not set the pump speed above 490 RPM.
9. Tighten locking nut.
10. Replace and tighten aluminium screw cap.
11. Monitor pump speed after initial adjustment to confirm that it remains stable and within the specified range of 300 to 550 RPM.

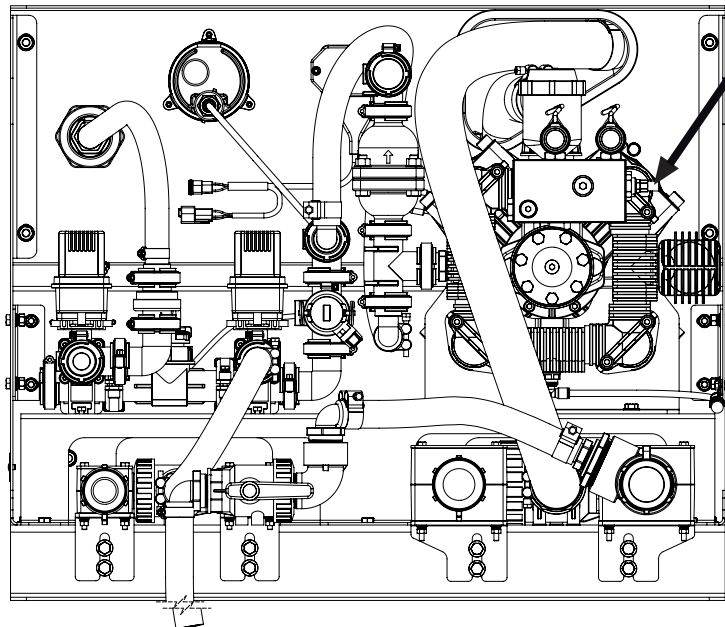

! CAUTION: Pump may run up to 50 RPM faster when hydraulic oil temperature increases with use so allow for this when setting up with cold oil.

! CAUTION: Higher pump speed will deliver greater liquid flow for application and tank agitation but do not exceed the maximum specified speed.

CONTROLLER CONFIGURATION

Refer to manufacturer's instructions for setting up electronic control systems. The following table provides a summary of the control system and device types.

Control System and device types	
Control Type	Servo valve in bypass configuration with separate master shutoff valve and flowmeter.
Servo Valve	12V, 2 wire input
Shutoff Valve	12V, 3 wire positively switched
Flow Meter	12V, Cal. Factor = 82 pulses/litre, 310 pulses/US Gal, 373 pulses/Imp Gal
Pressure Sensor	12V, 3 wire, 0-5V linear signal, range 0-10bar, 0-145 psi, Cal. Factor 500mV/bar, 34.5mV/psi
Pump RPM Sensor	Hall Effect Sensor, Cal. Factor 1 pulse/rev

CHECK DISTRIBUTION SYSTEM OUTLETS

Prior to using the system, check all outlets in the downstream distribution system are working by performing a Flush System (Static) Operation.

Refer to page 5.2 for instructions.

GREENSTAR RATE CONTROLLER CONFIGURATION

Refer to the John Deere Rate Controller Manual for details on how to configure the rate controller. The following values should be used when initially configuring the Rate Controller.

Implement Setup			
Implement Type	Pull-behind Sprayer		
Implement Name	Ai120 180 Upgrade		
Implement Width	Enter the width of the bar.		
Setup Sections	Configure a single section with full bar width.		
Dual Boom	Disabled		
System Setup			
Section Valve Type	3 Wire		
Control Valve Type	Standard		
Tank Capacity	Enter tank capacity.		
Control Valve Calibration	8023		
Flowmeter Calibration	82	310	373
Flowmeter Units	L	US Gal	Imp Gal
Pressure Sensor	Enabled		
Flow Return	Disabled		
Agitator Valve	Disabled		
Alarm Setup			
Minimum Pressure	0.7 bar	10 psi	
Maximum Pressure	7 bar	100psi	
Low Tank Level	1400 L	100 US Gal	90 Imp Gal
High Alarm	20%		
Low Alarm	20%		
Rates			
Rate 1, 2, 3	Enter required preset rates.		
Minimum Flow Rate	0.5 L/min	0.1 US Gal/min	0.1 Imp Gal/min
Rate Smoothing	Enabled 3%		

FLOW METER CALIBRATION

The Teejet flowmeter used in the Ai120 180 Upgrade Valve Set has a standard calibration factor of 82 pulses/litre (310 pulses/US Gal). This will usually provide reasonable accuracy when entered into an electronic controller. However, Liquid Systems (SA) recommends conducting a flowmeter calibration test of each flowmeter to ensure optimal system accuracy.

Applied Method

This method requires the operator to apply a known amount of liquid. Liquid Systems recommends using this method at a paddock scale when applying actual product. Measurement of actual amount applied can be achieved by any of the following methods:

- Measure the amount applied by marking a start level on the tank and then measuring with a separate high volume flowmeter the volume it takes to refill the tank to this level.
- Measure the amount of liquid into an empty tank with a separate high volume flowmeter. Apply all the liquid in the tank for the calibration run.
- Apply a complete tank of liquid and use the tank's specified volume for calibration.

Catch Method

This method involves catching and measuring an amount of liquid that the system outputs. Collect the output of the Ai120 module in a large bucket and accurately measure the amount collected. For either method, calculate the revised calibration factor use the following equation:

$$\frac{\text{New Cal Factor} = \text{Old Cal Factor} \times \text{Volume Applied (screen)}}{\text{Volume Applied (measured)}}$$

Some controllers have in built calibration functions that perform these calculations automatically. However, **always retest** after adjusting flowmeter cal factor to ensure the adjustment is correct.

OPERATIONAL TESTING

Liquid Systems (SA) recommends conducting extensive operational testing of the system with clean water prior to using the system for applying actual products.

Refer to the next section of this document for information on operation of the system.

NOTE: Depending on the physical properties of the product being applied, it may be more accurate to calibrate the flow meter using the actual product rather than water.

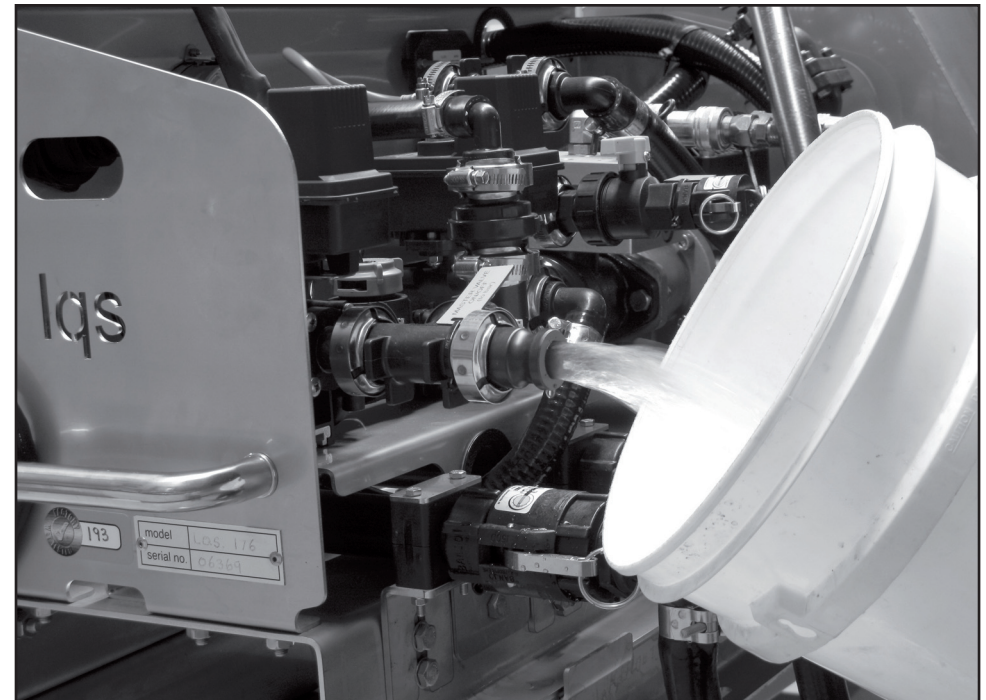

STARTUP

1. Turn source selector valve to “Product” and function selector to “Operate”.
(See Image Below)



2. Check hydraulic lines are connected to the Ai120 180 Upgrade module.
3. Check electric power is connected to Greenstar™ Rate Controller and Display.
4. Setup rates to be applied in the Greenstar™ Rate Controller via the Greenstar™ Display.
5. Start hydraulic flow to pump.
6. Liquid application can now be turned on and off by the Master On-Off switch.

MONITORING

Fertiliser application can be monitored via the Greenstar™ Rate Controller screens on the Greenstar™ Display. Refer to Greenstar™ documentation for instructions.

Things to look out for are:

- Sudden changes in pressure or actual rate applied.
- Low tank level
- Gradual increases in pressure when all other operational parameters remain the same may indicate outlets becoming blocked

FLUSH SYSTEM (STATIC)

The purge system allows bypass flow to be either dumped to ground or recycled. When purging with clean water, initial bypass flow should be dumped to ground to flush out pump and module. Bypass flow can then be recycled to complete purging of distribution system without using excessive amounts of water.

1. Stop tractor. Ensure brakes are effectively applied.
2. Stop hydraulic power to the Ai120 180 Upgrade module.
3. Switch source selector valve to “Clean Water” and function selector valve to “Purge” on the front of the module. **(See Image Below)**



! CAUTION: Running the Nozzle Flow Check test at a pressure above 5 bar (73 psi) may put water into the product tank via the pressure relief valve.

Liquid will flow from the purge dump line when function selector valve is set to “Purge” and Purge Dump valve is in “Dump” position.

Use of the Rinse Cycle function of the Greenstar™ Rate Controller will put water back into the product tank via the pressure relief valve.

If using this system with Section Control, ensure all sections are switched on before flushing otherwise water will flow back into the product tank.

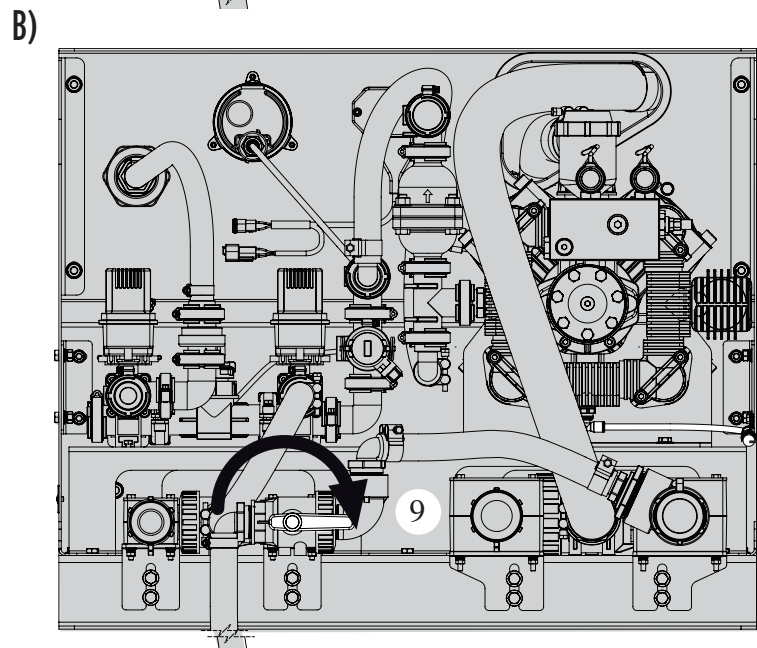
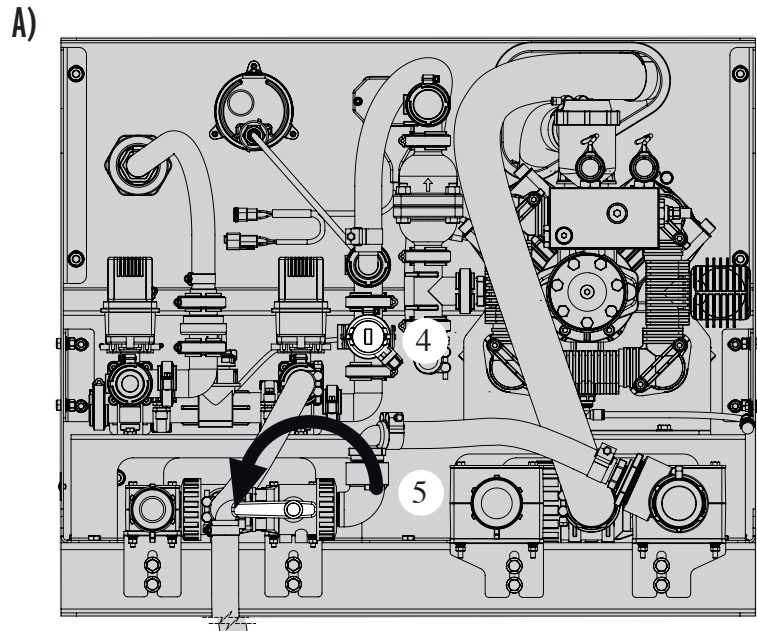

4. Turn off agitation at valve on Agitation Port.
5. Switch Purge Dump valve to Dump position. **(Handle Pointing Left)** (See **Image on A**)
6. If using section control, ensure all sections are on.
7. Use a test mode of the control system to run water through the liquid system for 10 seconds (e.g. Nozzle Flow Check in Greenstar™). Enter a ground speed and application rate to create a system pressure of approximately 5 bar (73 psi). To avoid excess clean water use, start the pump immediately prior to initiating flow via control system.
8. Stop pump via hydraulics immediately after 10 seconds of flow.
9. Switch Purge Dump valve to Recycle position. **(Handle Pointing Right)** (See **Image B**)
10. Use a test mode of the control system to run water through the liquid system at approximately 5 bar (as per step 7).
11. Check all outlets are flowing. Stop pump to clear any blockages and then re-test.
12. Maintain flow until all outlets are running clear.

SHUTDOWN

When planting and fertilising operation is complete.

1. Drain Product Tank
2. Rinse Product Tank with clean water
3. Flush the module and Distribution System with clean water.
4. Drain Clean Water Tank
5. In climates where temperatures drop below freezing, fill Clean Water Tank with pre-mixed automotive antifreeze and perform a static System Flush.
6. (Export Modules only) Drain pump by removing push-in plug from Pump Manifold Drain.

FLUSH SYSTEM

Frequency - When in use once daily and when the system is to be shut down for an extended period.
Refer to Flush System (Static) instructions in Section 5.

CHECK & CLEAN SUCTION FILTER

Frequency - twice daily when system is in operation.

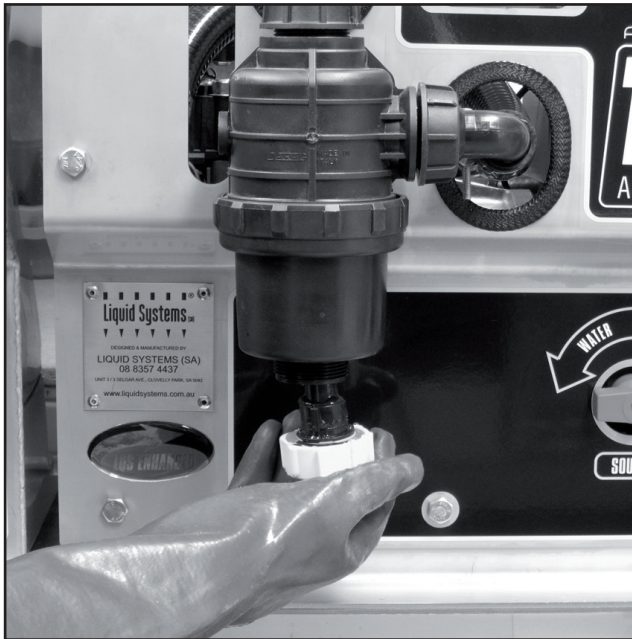

1. Remove yellow end cap. Catch any escaping liquid in a bucket.

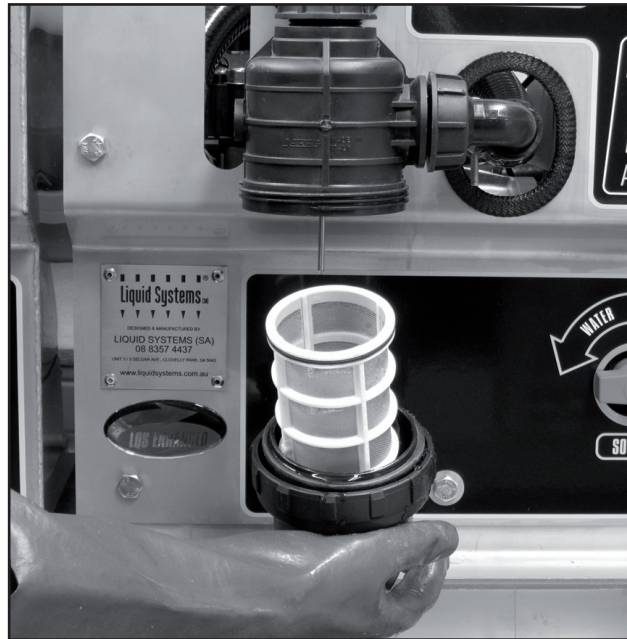

2. Unscrew filter bowl from body.
3. Inspect and clean screen. Replace screen if damaged.
4. Check seating of O ring.
5. Replace screen and screw bowl back into place
6. Replace end cap.

Refer to the spare parts section of this manual for replacement parts.

⚠ WARNING: Liquid will escape from the filter during this process. Ensure suitable protective gloves and clothing are worn when performing this task.

CHECK PUMP OIL LEVELS

Frequency – daily when system is in operation. Check pump oil levels in reservoirs as shown below. If oil level is low, top up with SAE 30 oil. Discoloured oil or loss of oil indicates a problem.

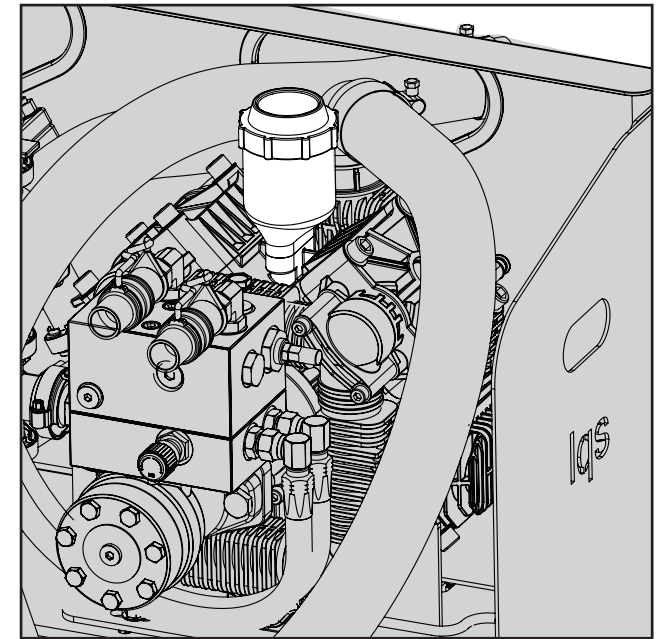

Refer to Bertolini 2180 Pump Manual for maintenance instructions.

⚠ CAUTION: It is important when reassembling the suction filter that the screen bowl assembly be re-located correctly to the filter body. The pin location is crucial to operation of the filter. The pin activates a valve that will prevent the pump from sucking liquid if it is not seated correctly.

FLUSH DISTRIBUTION SYSTEM - MANUAL

If the clean water tank is empty the downstream Stacker Distribution Systems can be flushed using the external flush port.



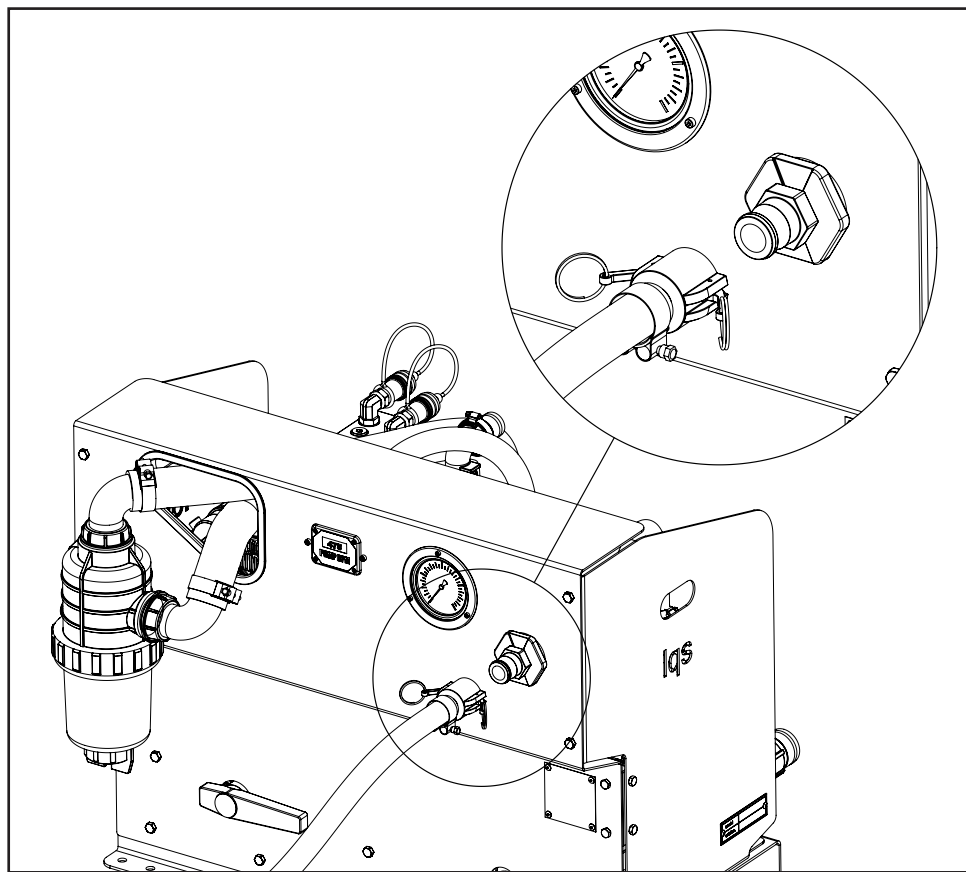

1. Attach a clean water hose to the external flush port using a 1" female camlock coupling. A non-return valve prevents flow of liquid out of the flush port.
2. Run clean water through system for 5 minutes.
3. While water is running check to make sure all Distribution System outlets are delivering an even unbroken stream. Clear any blockages. Refer to Stacker Distribution System Manual for Instructions.
4. Turn off water, disconnect hose and replace dust cap on external flush port.

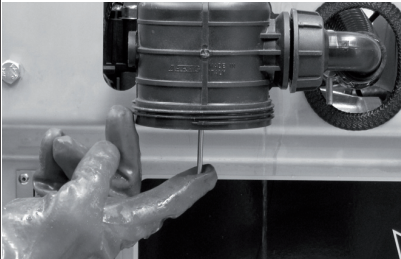





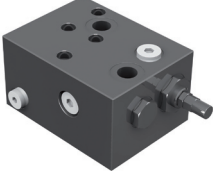





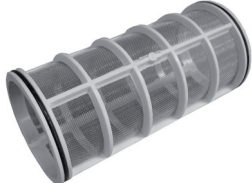

! CAUTION: If using this system with Section Control, ensure all sections are switched on before flushing otherwise water will flow back into the product tank.

PROBLEM	POSSIBLE CAUSE	RESOLUTION
<p>Pump Won't Suck</p>	<p>Air in suction line.</p> 	<p>Air in the suction lines may prevent the pump from sucking liquid. Air can be vented on the suction side via the suction filter.</p> <ol style="list-style-type: none"> 1. Undo yellow end cap and unscrew filter bowl. 2. Press up against valve pin to vent air from suction lines. 3. When liquid starts flowing out of the suction filter, release pressure on valve pin. 4. Replace filter bowl and yellow cap.
	<p>Blocked Suction Filter</p>	<p>Check and Clean Suction Filter. Refer to Maintenance section for instructions.</p> <p>It is important that after the suction filter screen has been inspected and cleaned that the screen bowl assembly be re-fitted correctly to the filter body (The valve pin location is crucial to operation of the filter).</p>
	<p>Air Leak on Suction Side of Pump</p>	<p>Check hoses and fittings for splits and correct seating.</p>
	<p>Obstruction on Suction Side of Pump</p>	<p>Check all hoses fittings. Check source selector valve is in correct position. Check tank suction outlet valve is open.</p>
	<p>Pump Fault</p>	<p>Pump faults that may occur include broken valve springs, debris in valves or damaged diaphragms. Overhaul pump to check valves and diaphragms.</p>
<p>Pump Noisy / Banging</p>	<p>Excessive hydraulic flow from tractor.</p>	<p>The pump is speed protected via a flow control block fitted to the pump's hydraulic motor. Excessive hydraulic flow from the tractor may trigger its own hydraulic relief system into play causing 'hammering'. This can be difficult to diagnose as it may appear that the hammering is coming from the pump itself.</p> <p>Reduce hydraulic flow from the tractor - (a flow of approx. 20-22lpm. should provide sufficient pump speed)!</p>
<p>Rapid loss of pump oil</p>	<p>Split diaphragm or leaking end seal.</p>	<p>Check to see if oil is leaking around end seal. Check diaphragms for splits. Replace seal or diaphragms as necessary. Refer to Bertolini pump manual for details.</p>

PROBLEM	POSSIBLE CAUSE	RESOLUTION
No Rate Control Actual Rate Too HIGH	Restrictive devices in distribution system are too large. This will also be indicated by low system pressure.	Metering system (on tillage bar) restrictive devices too large. - (This causes excessive leakage within the metering system downstream from the servo valve). When this happens (usually when the operator is attempting very low rates), there is insufficient back pressure to stabilise the system. Under these circumstances the servo will attempt to compensate by fully opening back to tank when in reality the liquid has already escaped - consequently there is no system control. Fit smaller restrictors in the distribution system.
	Tank agitation line switched off or too restricted.	Check agitation valve at rear of module. If valve is closed, open it up and retest system with target rates. Check size of nozzle in agitator, install a larger nozzle or remove the nozzle altogether. Different agitator nozzle sizes are available from your dealer. Agitators should be installed so as to provide agitation at bottom of tank.
	Excessive Flow from Pump	If actual rate is still too high, reduce flow from pump. Refer to 4.1 CHECK AND ADJUST PUMP SPEED for instructions.
No Rate Control Actual Rate Too LOW	Restrictive devices in distribution system are too small. This will also be indicated by high system pressure.	If the restrictive devices are too small then the pressure will exceed the PRV setting. The PRV will bypass liquid back to tank and the regulating control valve then becomes ineffective. Fit larger restrictors in the distribution system.
	Inadequate restriction on tank agitation line	Check tank agitator is installed on end of tank agitation line. Install a smaller size agitator nozzle to increase restriction. Different agitator nozzle sizes are available from your dealer. Agitators should be installed so as to provide agitation at bottom of tank.
	Insufficient Flow from Pump	If actual rate is still too low, increase flow from pump. Refer to 4.1 CHECK AND ADJUST PUMP SPEED for instructions.
No Rate Control or Wildly Fluctuating Rates	Servo valve polarity is incorrect.	Check Servo valve polarity - (servo valve opens when it should be closing). Use the Control Valve Test function of the Greenstar™ Rate controller. Pressing the “+” button should close the valve and “-” should open it.
	Pump not functioning properly.	Pump may not be performing properly. This could be due to suction, discharge or speed problems. Suction Filter may be blocked or inlet to pump impaired (broken valve spring, debris in valve etc.). Pressure side of pump may be impaired - (broken valve spring, debris in valve etc.). Pump may not be operating at a constant speed due to erratic hydraulic flow from tractor. Check and Clean Suction Filter / Check hydraulic flow to pump.
	Incorrectly fitted, faulty or damaged speed sensor.	Test the speed sensor against tractor speedometer.
	Faulty Flowmeter	Perform repeat flowmeter calibrations. Check for consistency of results
	Faulty Servo Valve	Use the Control Valve Test function or manual override in control system to check servo valve is working.
	Over-responsive Servo Valve	Adjust responsiveness of servo valve in control system configuration.

PUMP	PART NO.	DESCRIPTION
	BE-62.0040.36.2	HPS Diaphragm for 2180 pump. (4 x Diaphragms required for 2180 pump)
	BE-28.9809.97.3	Valve Kit for 2180 Pump 8 x 28.9809.97.3 (SS Valves) 8 x 80.3314.00.2 (Orings 4,5 x 40) 4 x 80.3209.40.2 (Orings 2,62 x 44,12)
	BL-689904-20	Flow Control Block 20 LPM (6.6 US gallons pm)
<h3>SUCTION FILTER</h3>		
	AG-3172472	2" 32 mesh Suction Filter
	AG-116750	2" - Hose Tail 90 Degree

SUCTION FILTER <small>CONT.</small>	PART NO.	DESCRIPTION
	AG-G10071	O'-Ring for 2" Fly Nut
	AG-2002070	2" Fly Nut
	AG-3172002.030	2" Suction Filter 32 Mesh Screen
SELECTOR VALVES		
	AG-45531116	1½" 3 Way Ball Valve (Continuous Flow)
	AG-454236H.020	1½" 3 Way Ball Only (Continuous Flow)
	AG-45531117	2" 3 Way Ball Valve (Continuous Flow)
	AG-454237H.020	2" 3 Way Ball Only (Continuous Flow)

VALVE SET COMPONENTS	PART NO.	DESCRIPTION
	TJ-57-10100	TeeJet 801 Flowmeter
	TJ-461BEC-2F-C	460 Manifold Shut Off Valve
	TJ-56610-18-460BR	Liquid Systems Custom TeeJet 460 Regulating Valve
	WK-505.888.116962	Dual Scale (10 bar/140psi) Liquid Systems Stainless Steel Pressure Gauge with 3 Hole Flange only
	LL03003	Dual Scale (10 bar/140psi) Liquid Systems Stainless Steel Pressure Gauge with 3 Hole Flange & fixings

As an option the Ai120 180 Upgrade Module can be installed with a downstream Section Control module (part of a Stacker Section Control Configuration). This allows the liquid distribution system to be split into a number of sections where each section can be turned on and off during the seeding operation.

Some electronic rate control systems do not provide a separate master shutoff signal in addition to section shutoff signals. In these cases the Ai120 180 Upgrade will be supplied with the shutoff valve replaced by a simple mechanical non-return valve. (SC Configuration)

Ai120 180 Upgrade MODULE SC CONFIGURATION for use with STACKER SECTION CONTROL CONFIGURATIONS

The drawing below shows the shut-off valve is replaced by the non return valve.

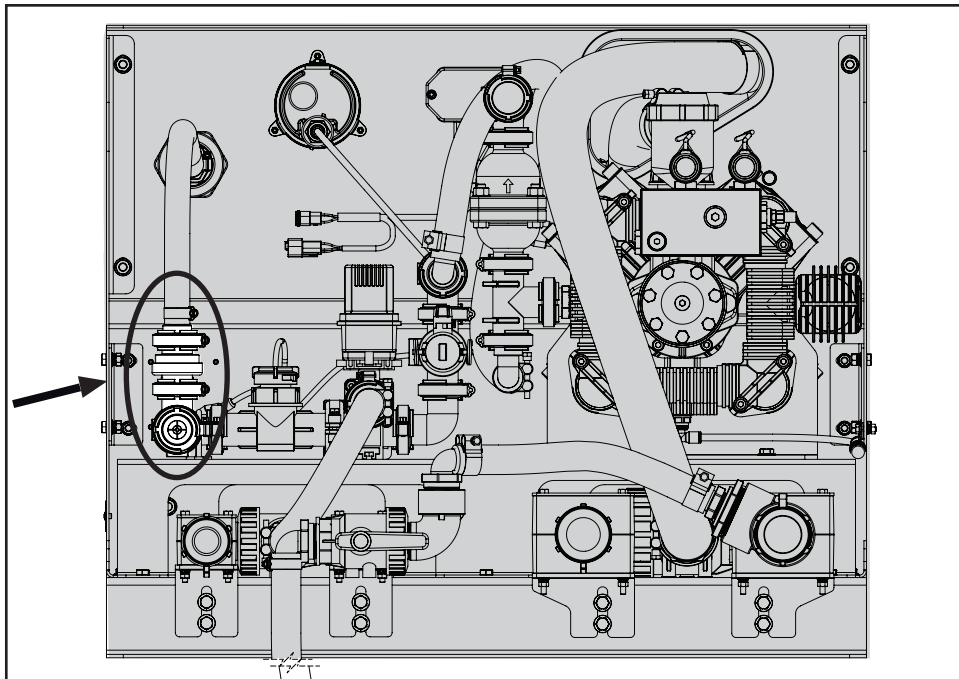

INSTALLATION

Refer to your Stacker Section Control Configurations Operators Manual for instructions on installation and operation of Section Control module in conjunction with the Ai120 180 Upgrade.

NOTE: IMPORTANT to read all Manuals carefully before installation.

