



LQS120 OPERATORS MANUAL

Version 2.1



PLB Australasia Pty Ltd trading as Liquid Systems (SA)

www.liquidsystems.com.au

TABLE OF CONTENTS

1. IMPORTANT INFORMATION

SAFETY & DAMAGE WARNINGS.....	1.1
IMPORTANT SAFETY INSTRUCTIONS	1.1

2. SPECIFICATIONS

ABOUT THE SYSTEM	2.1
HYDRAULICS	2.1
ELECTRICAL	2.1
MODULE INFORMATION.....	2.1
MODULE COMPONENTS	2.2
LQS120 SYSTEM LAYOUT	2.3

3. INSTALLATION

MOUNT MODULE	3.1
INSTALL SUCTION LINES X2	3.1
INSTALL SERVO BYPASS RETURN LINE.....	3.2
INSTALL PURGE DUMP LINE	3.3
INSTALL UMBILICAL LINE.....	3.4
CONNECT ELECTRONICS.....	3.5
CONNECT HYDRAULICS	3.5
CONNECT HYDRAULICS - ADD MODULE IN SERIES	3.6

4. PRE-OPERATIONAL CALIBRATION & TESTING

CHECK AND ADJUST PUMP SPEED.....	4.1
TEST OPERATION	4.1
CALIBRATE FLOWMETER	4.1

5. OPERATION & MAINTENANCE

OPERATE SYSTEM.....	5.1
MONITORING	5.1
CHECK PUMP OIL LEVEL.....	5.1
FLUSH SYSTEM (STATIC).....	5.2
FLUSH DISTRIBUTION SYSTEM (MANUAL).....	5.2
CHECK & CLEAN SUCTION FILTER.....	5.3
SHUTDOWN.....	5.3
FILL PRODUCT TANK.....	5.4
MODULE REAR ACCESS.....	5.5

6. REPLACEMENT PARTS

PUMP COMPONENTS.....	6.1
SELECTOR VALVES	6.1
SUCTION FILTER.....	6.2
VALVE SET COMPONENTS	6.2

SAFETY AND DAMAGE WARNINGS

WARNING, CAUTION and NOTE symbols are used throughout this manual to stress the importance of personal safety, potential machinery damage and useful operating information.

Symbol Descriptions shown below:



WARNING: Indicates the strong possibility of severe personal injury or damage to machinery if instructions are not followed.



CAUTION: Highlights hazards, unsafe or unwise practices which could cause personal injury, property damage, damage to your machinery or loss of potential crop yield if instructions are not followed



NOTE: Refers to important and useful information which should not be overlooked.

IMPORTANT SAFETY INSTRUCTIONS



WARNING:

Always wear protective gloves, eyewear and clothing when dealing with liquid fertilizers and other liquid agricultural products.

Do not disconnect any hose lines while the pump is running.

Ensure power is switched off or disconnected when connecting or disconnecting any electrical components of the system.

Always ensure the tank lid or a vent/overflow valve is open to allow air to escape when filling product tank.



WARNING: Use of phosphoric acid with this equipment will void the warranty.

ABOUT THE SYSTEM

The Pump & Control Module is designed to provide accurate, rate controlled variable application of liquid fertilizers & other crop care products.

HYDRAULICS

Displacement per Revolution	50cc
Max Operating Speed	550 rpm
Max Hydraulic Pressure	1500 psi
Max Hydraulic Flowrate	30 L/min, 7.9 US Ga/min, 6.6 Imp. Ga/min

ELECTRICAL

Nominal Voltage	12V DC
Maximum Current	1.3A
Flowmeter Calibration	82 Pulses/L 310 Pulses/US gal 373 Pulses/imp gal
Pump Speed Sensor	36 pulses/revolution
Pressure Sensor	5mV/kPa 34.5mV/psi

MODULE INFORMATION

Unit Weight	109Kg
Safe Operating Range	1-5.5 bar 14-80psi
Flow Control Range	7- 120 L/min 2- 31 Gal/min

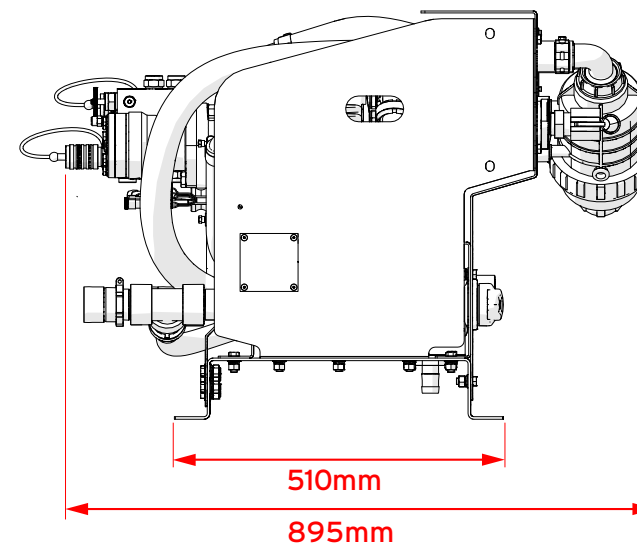
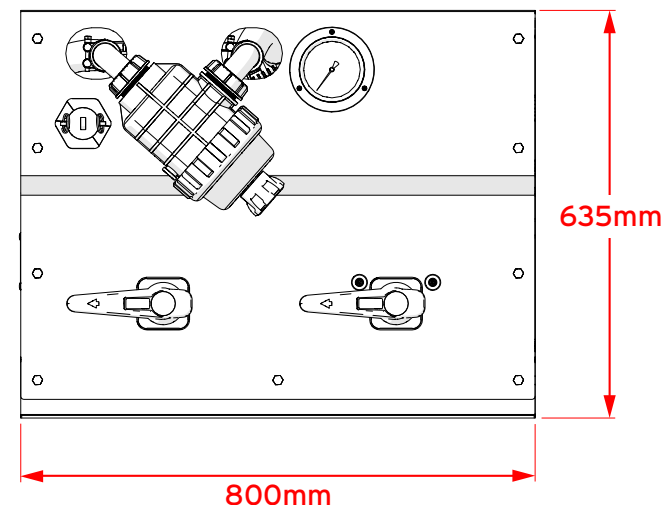

MODULE COMPONENTS

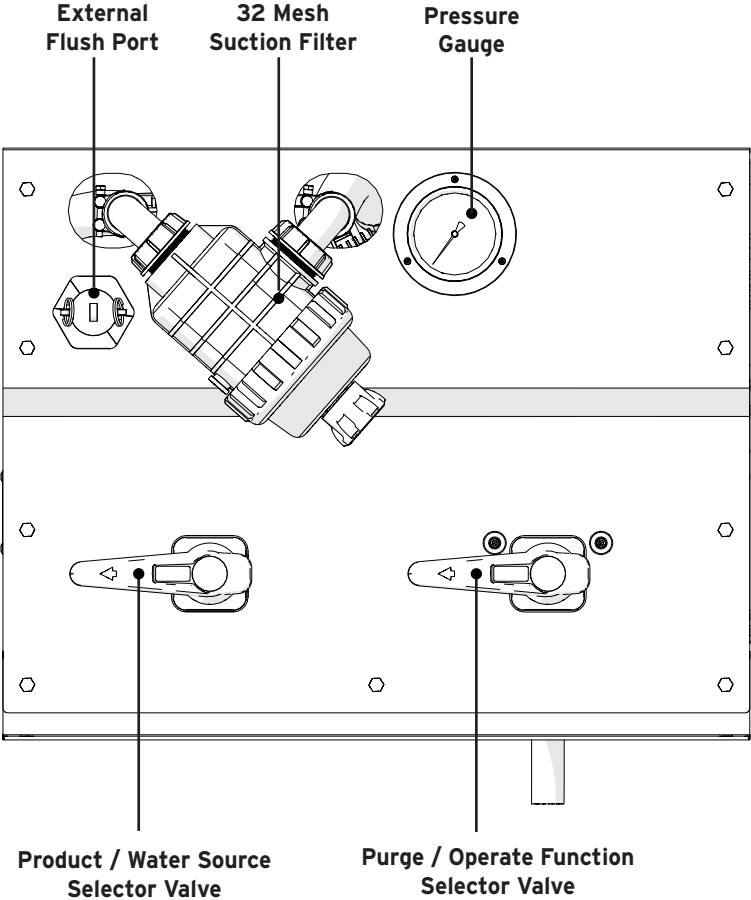

FRONT VIEW

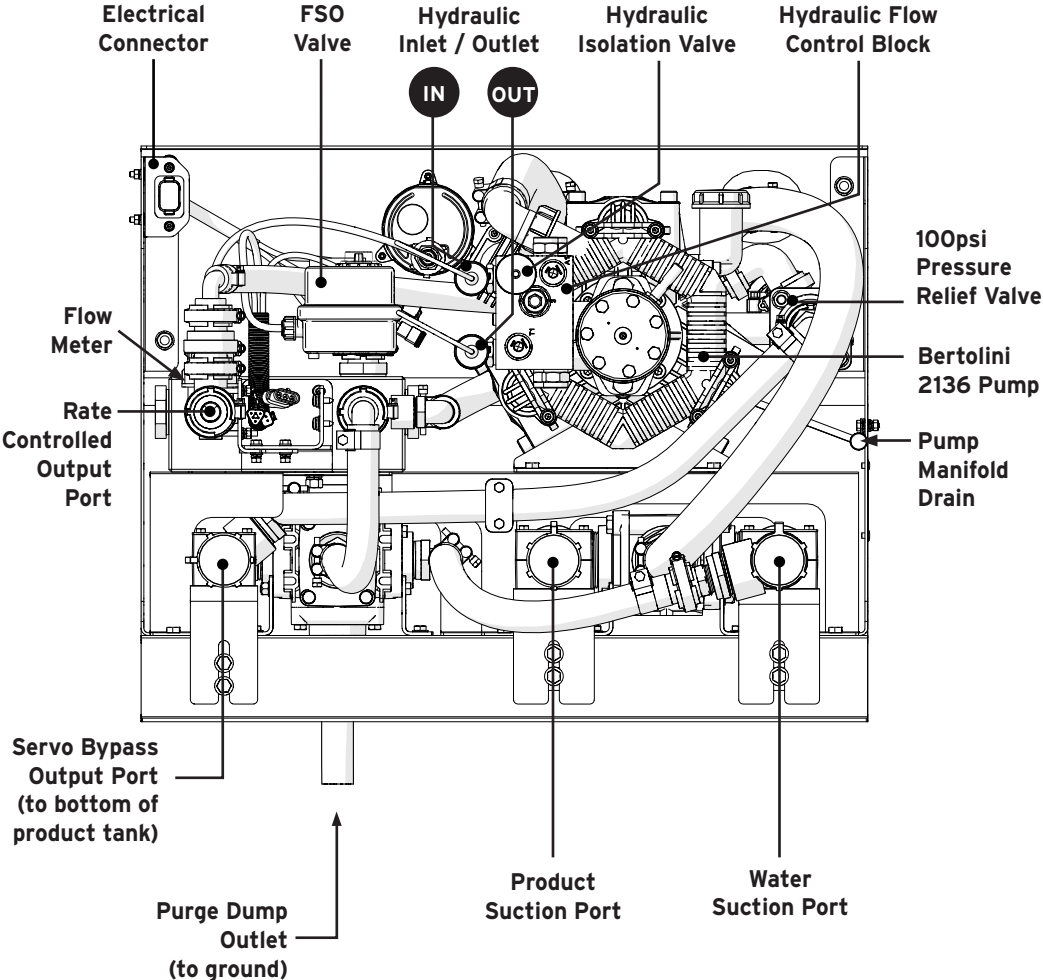

BACK VIEW

LQS120 SYSTEM LAYOUT

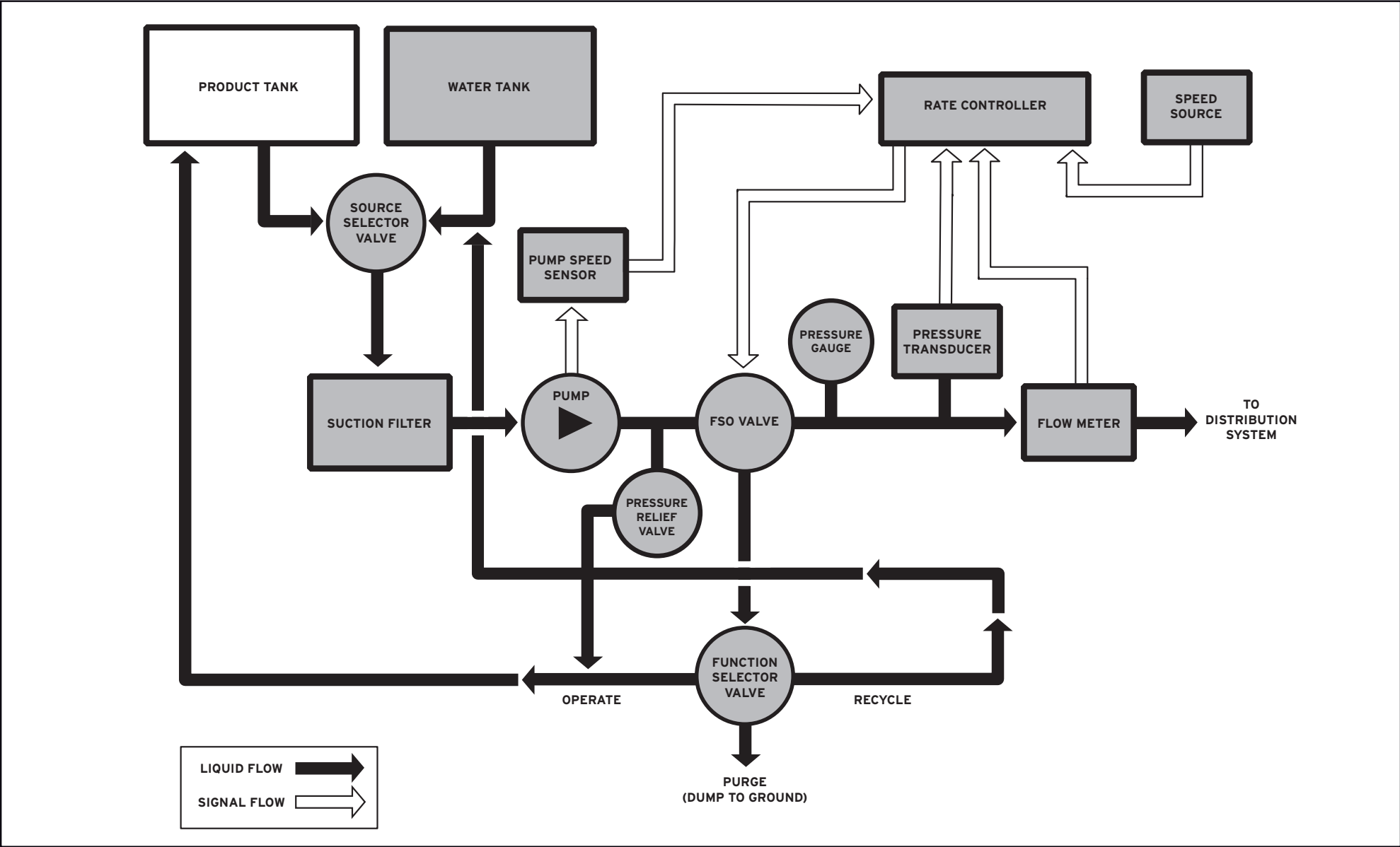

MOUNT MODULE

- Build framework for mounting of module. Refer to page 2.1 for dimensions.
- Ensure the mounting of the module does not interfere with functionality of implement. E.g. Steering, Augers, fans.
- Ensure hardware used for mounting will support the weight of the module.

INSTALL SUCTION LINES X2

Connect suction lines to product & water tanks.

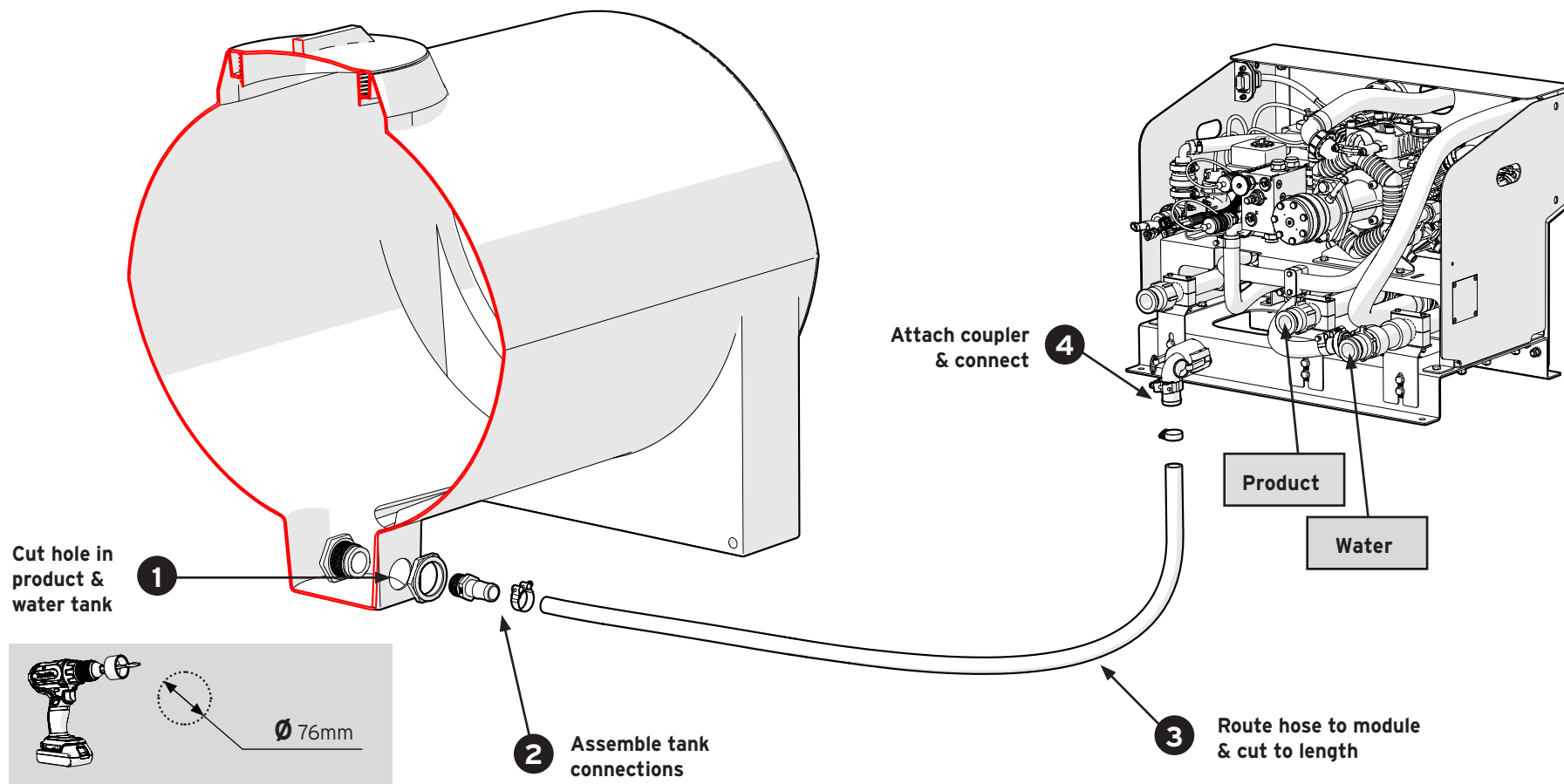

INSTALL SERVO BYPASS RETURN LINE

Connect to Product Tank

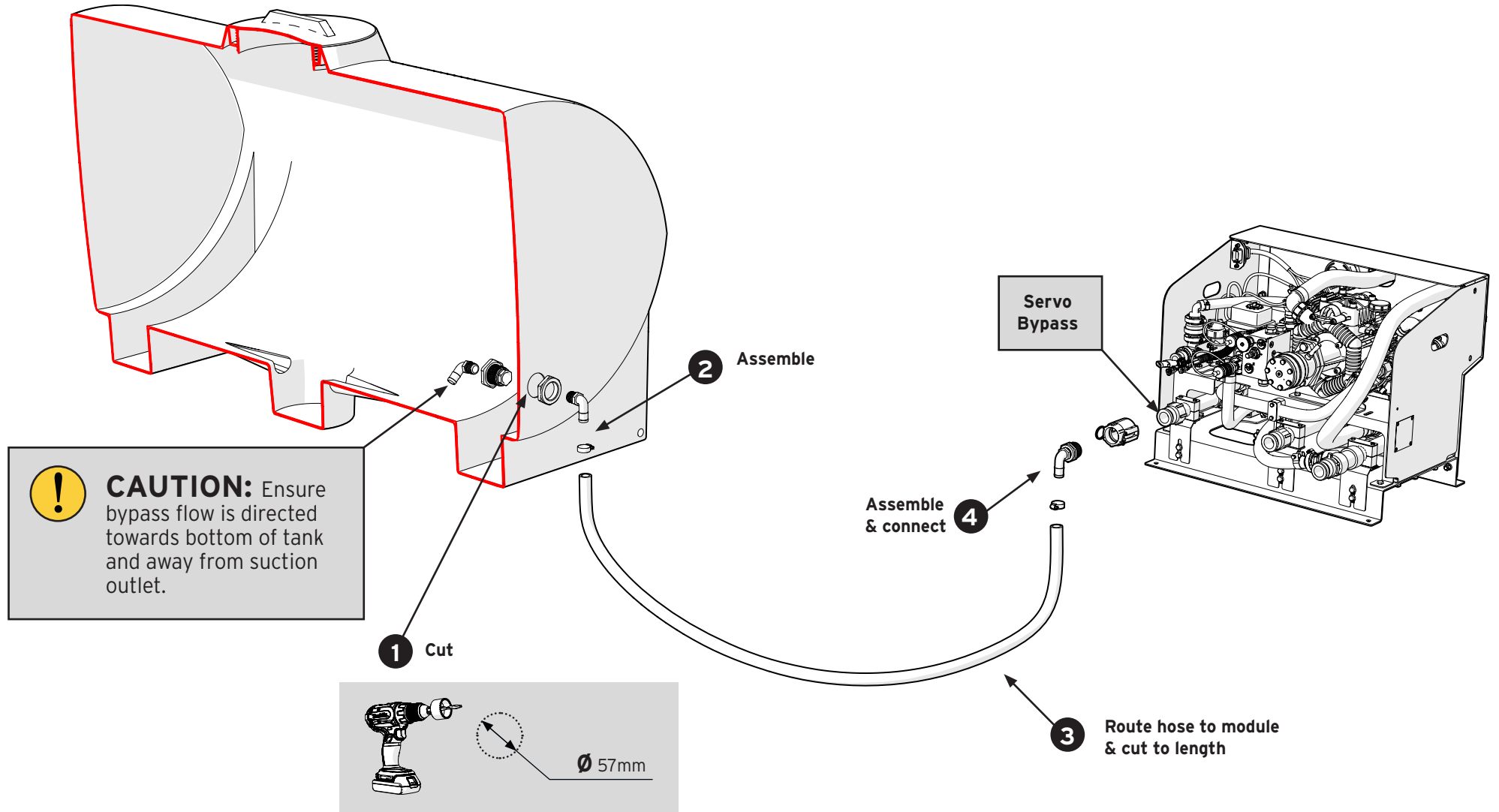

INSTALL PURGE DUMP LINE

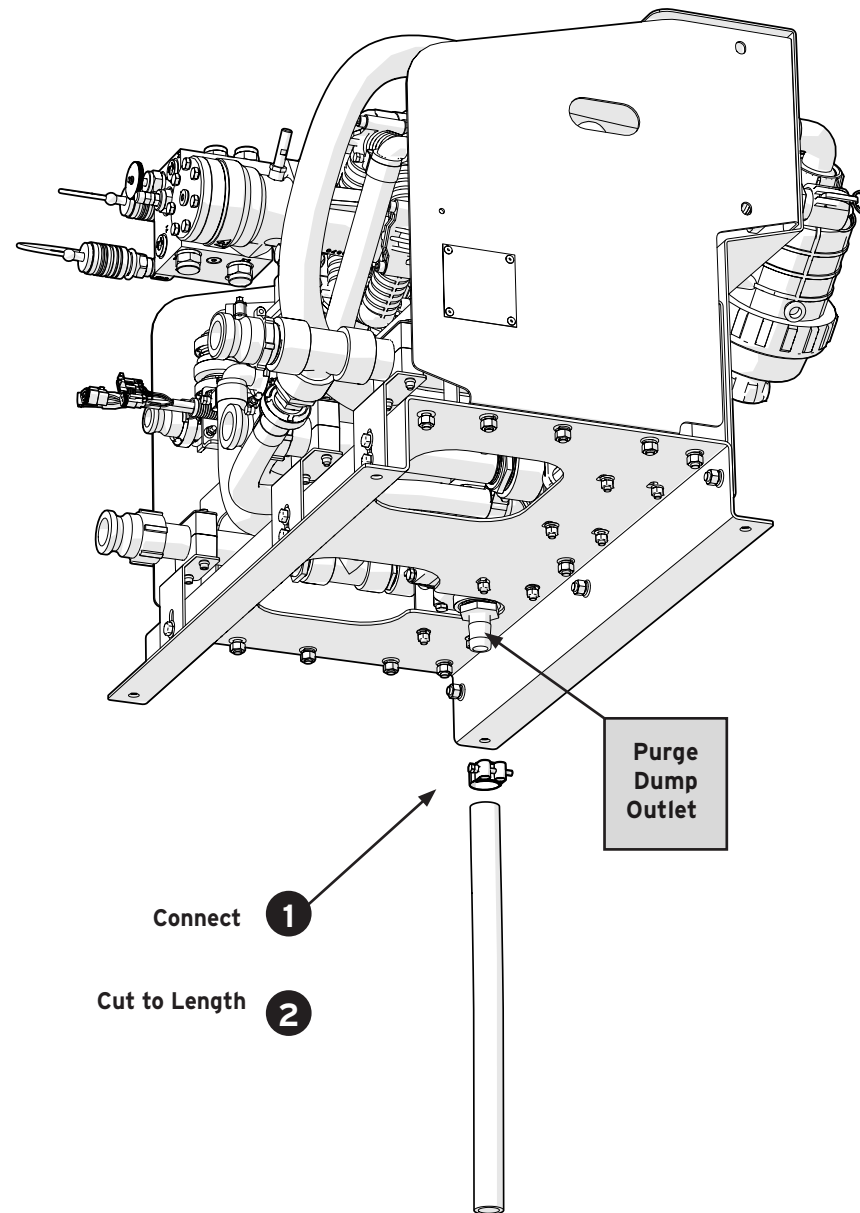

INSTALL UMBILICAL LINE

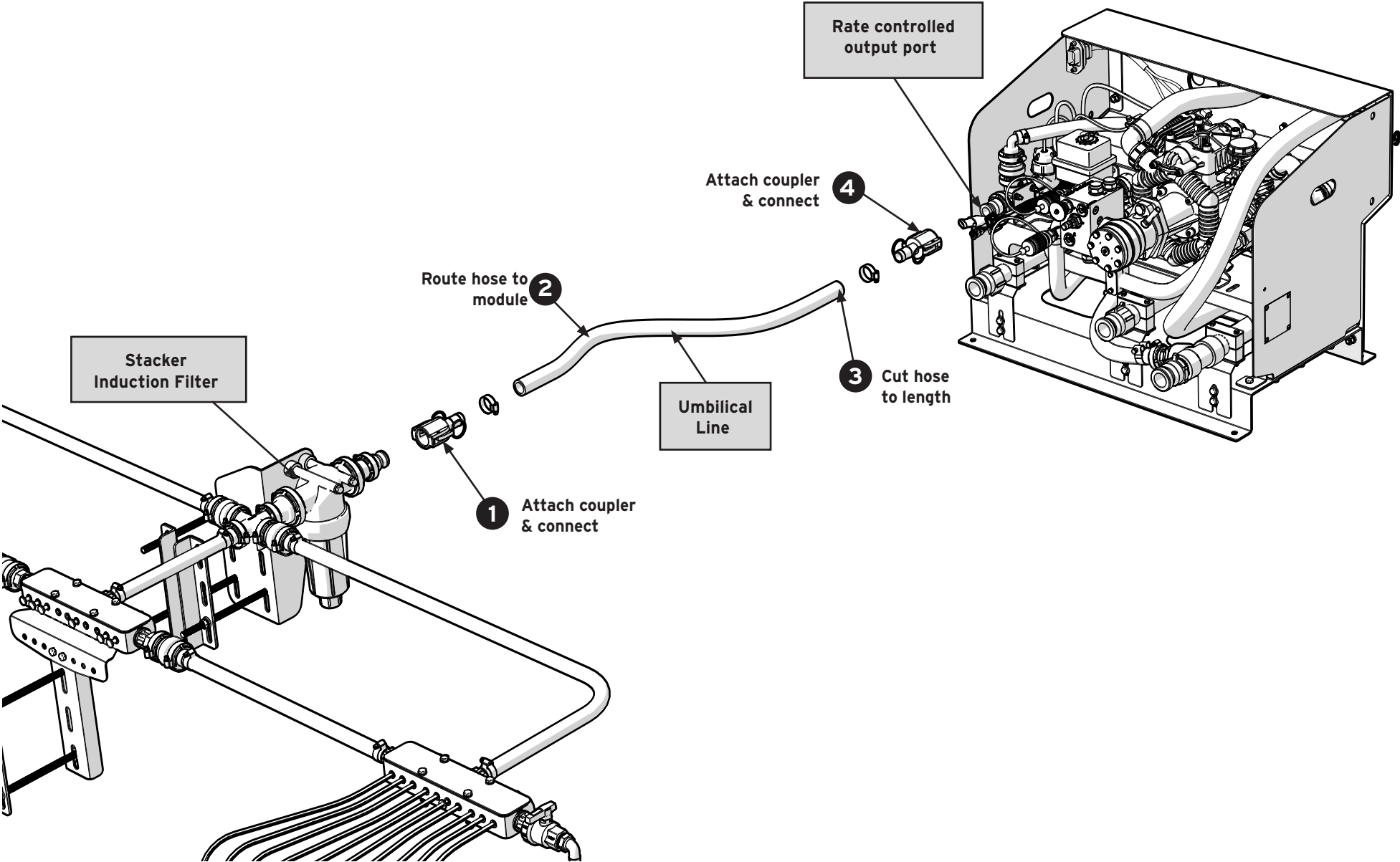

CONNECT ELECTRONICS

Refer to LQS Controller Setup Guide and manufacturer's controller and display manuals.

1. Plug individual device connectors on the module to matching connectors on generic module loom.
2. Connect generic module loom to controller specific adaptor loom.
3. Connect adaptor loom to controller.
4. Configure Control System.



WARNING: Ensure electrical power is disconnected from Controller before connecting the adaptor harness.

CONNECT HYDRAULICS

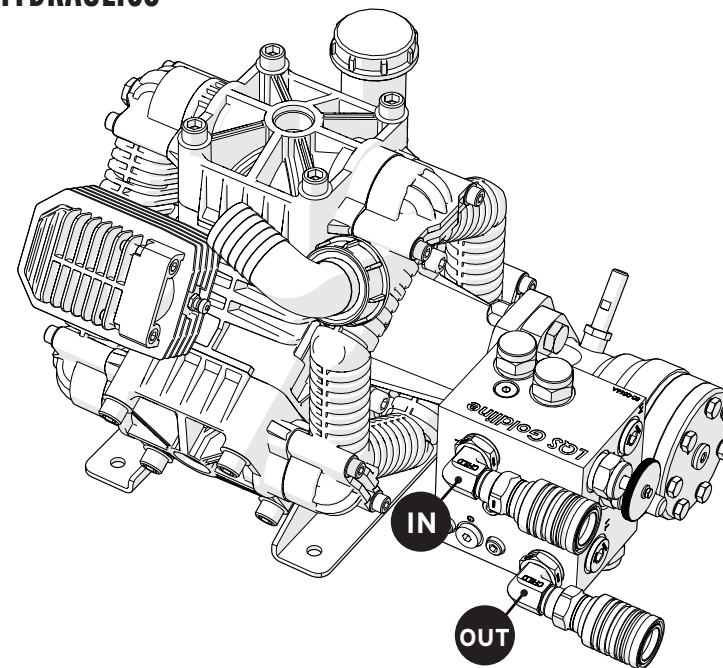

Connect 1/2" hydraulic lines to couplings on hydraulic flow control block with male fittings supplied. Use a dedicated pair of remotes on tractor.



NOTE: Hydraulic inlet is marked **P** and outlet is marked **T** on the flow control block. Ensure hydraulic input and output lines are fitted to the correct couplings otherwise pump will not run.



WARNING: Do not connect hydraulics in series with any other equipment unless specifically instructed to by Liquid Systems (SA).

CONNECT HYDRAULICS - ADD MODULE IN SERIES

A second module can be added for application of two liquids with independent auto-rate control. Follow below steps to connect 2 modules in series.

1. Remove Plug from port **5** on the Flow Control Block (FCB) of primary pump and replace with Cavity Plug (P/No. SO-CPLG-10-N-20-000).
2. Remove Plugs from ports **T1** and **A1** on the FCB of primary pump and replace with Male Nipples (P/No. SO-CP2-0814).
3. Connect first hose from port **A1** on the FCB of primary pump to port **P** on the FCB of secondary pump.
4. Connect second hose from port **T1** on the FCB of primary pump to port **T** on the FCB of secondary pump.

Apply steps 1 to 4 to the FCB of the second pump if there are 3 pumps in series.

Any pump can be disengaged by turning the Isolation Valve fully anti-clockwise.



NOTE: Turning off 1 pump may result in the other pump(s) running faster.

Increasing load on 1 pump (i.e. higher pressure application) may impact speed of other pump(s).

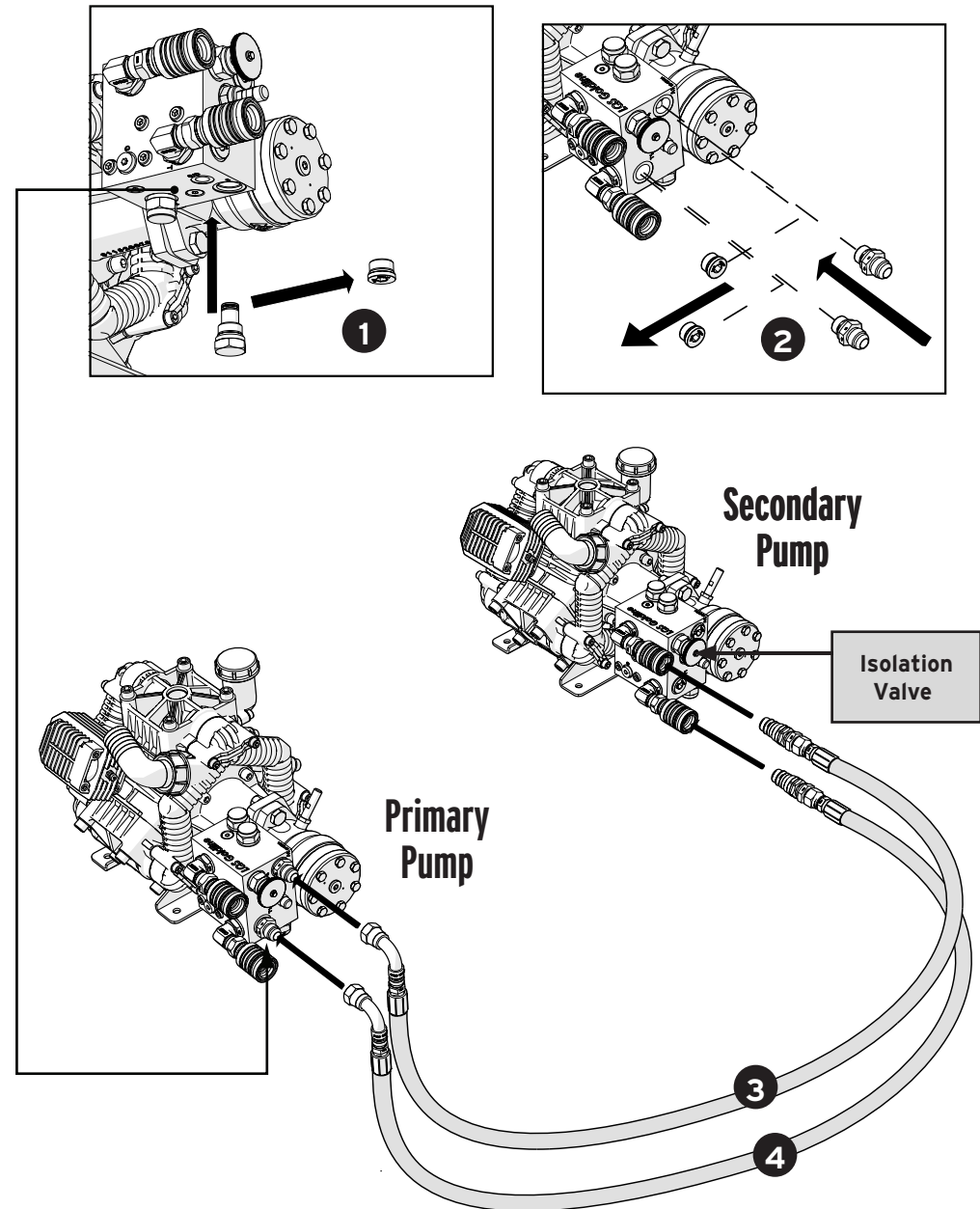

CHECK AND ADJUST PUMP SPEED

Pumps are factory set to 420 RPM. If lower or higher flow is required, control block can be adjusted to set maximum pump speed.

1. Configure controller to show pump speed on screen. Sensor generates 36 pulses/revolution.
2. Ensure selected source tank contains water or liquid product.
3. Ensure isolation valve is rotated fully clockwise.
4. Apply hydraulic power to pump.
5. Check pump speed on the display screen.
6. Remove 1/2" cap from control block.
7. Loosen 9/16" lock nut.
8. Use 3/16" Allen key to adjust speed - anti-clockwise to increase
9. Set speed within range MIN 300 RPM - MAX 550 RPM
10. If hydraulic oil is cold MAX RPM is 500.
11. Tighten lock nut. Replace and tighten cap

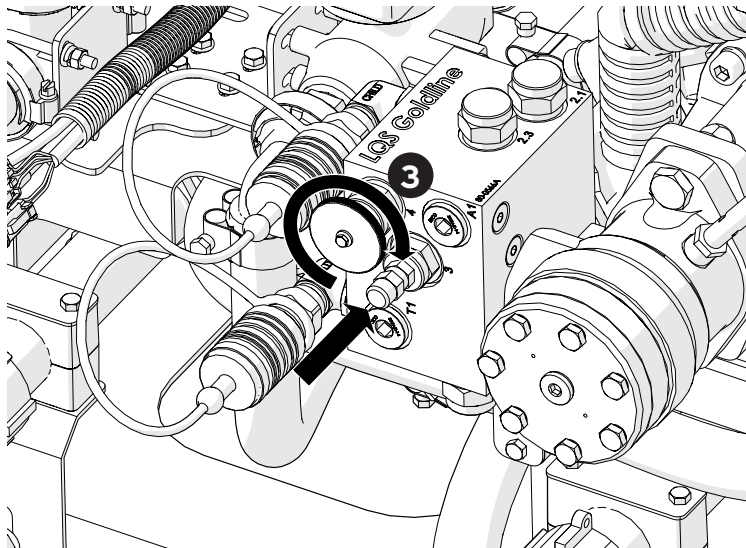

TEST OPERATION

- Run system with clean water to verify rate control for target application range.
- Check all distribution system outlets are working. Clear any blockages.
- Refer to next section of this document for instructions.

CALIBRATE FLOWMETER

- To calibrate flow meter, apply a known amount of liquid and compare actual volume applied with control system.
- You can use a full tank or an amount between marked levels on the tank. Alternatively, measure amount delivered out of a number of outlets for 1 minute and calculate equivalent for all outlets.
- Calculate the new calibration factor with the following:

$$\text{New Cal Factor} = \frac{\text{Current Cal Factor} \times \text{Volume Applied (controller display)}}{\text{Volume Applied (measured)}}$$



NOTE: Pump will not run at full speed unless isolation valve is rotated fully clockwise.



NOTE: Liquid product & water calibrations will normally be different.



CAUTION: Pump may run up to 50 RPM faster when hydraulic oil temperature increases with use so allow for this when setting up with cold oil.



CAUTION: Higher pump speed will deliver greater liquid flow for application and tank agitation but do not exceed the maximum specified speed.

OPERATE SYSTEM

1. Turn Source Selector Valve to **PRODUCT**
2. Turn Function Selector Valve to **OPERATE**
3. Setup application rates via the Display
4. Start hydraulic flow to pump
5. Enable product application via the Display

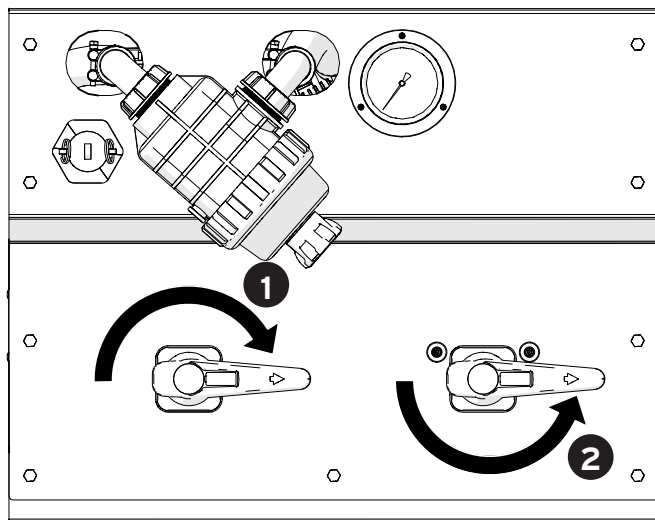

MONITORING

Monitor via Display

- Tank Level
- Changes in operating pressure
- Stability of Application Rate

CHECK PUMP OIL LEVEL

- Top up with SAE30 oil.
- If oil is discoloured, replace broken diaphragms.
- If reservoir is empty, replace worn shaft seal.

Refer to Bertolini pump manual for instructions.

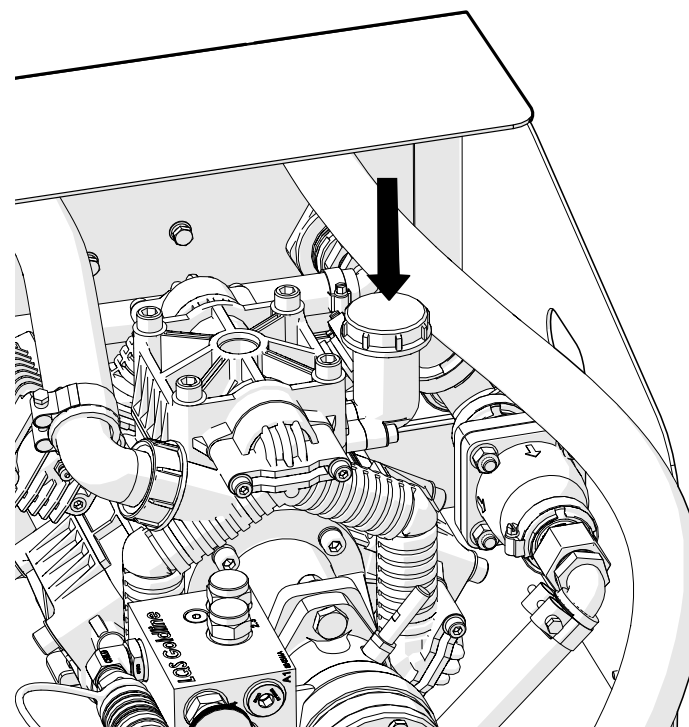

FLUSH SYSTEM (STATIC)

1. Turn Source Selector Valve to **WATER**
2. Turn Function Selector Valve to **PURGE**
3. Switch on all Sections in Controller
4. Start Pump
5. Run System in Controller Test Mode < 550kPa, 80psi
6. Check **ALL** outlets are flowing. Clear blockages.

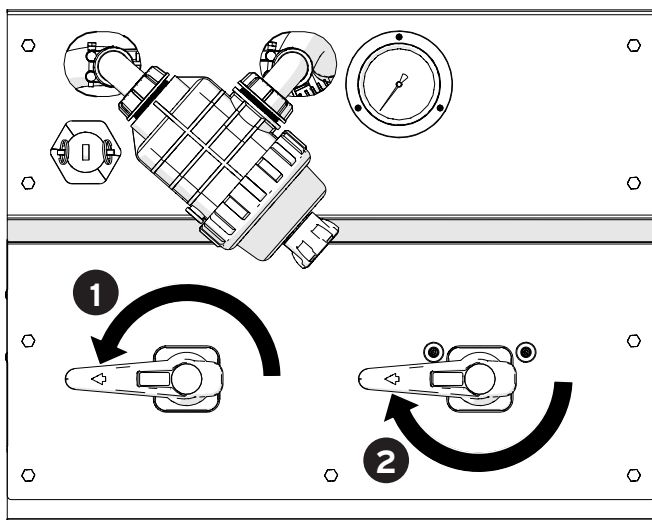

CAUTION: Flushing System at pressure above 5.5 bar (80 psi) may dilute product tank with water. With a Section Control system, ensure all sections are switched on before flushing. Otherwise water will flow back into product tank. Liquid will flow from the purge dump line when moving function selector valve from "Operate" to "Purge". Keep feet clear.

FLUSH DISTRIBUTION SYSTEM (MANUAL)

1. Connect to clean water
2. Switch on all Sections in Controller
3. Pump water < 550kPa, 80psi
4. Check ALL outlets are flowing. Clear blockages.

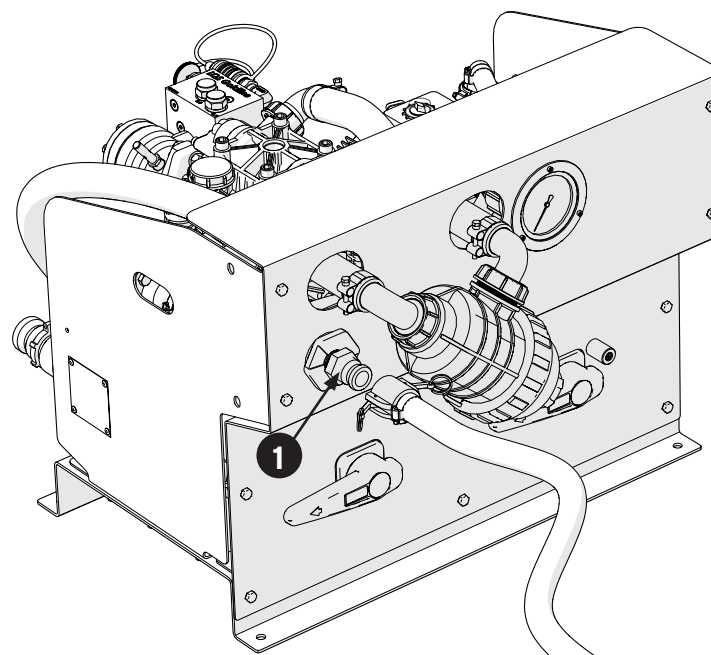

NOTE: A daily System Flush is good practice to keep system in optimal condition.

CHECK & CLEAN SUCTION FILTER

1. Unscrew plug to drain liquid from bowl
2. Unscrew fly nut to remove bowl
3. Clean screen. Replace if damaged
4. Check O-rings. Replace if damaged

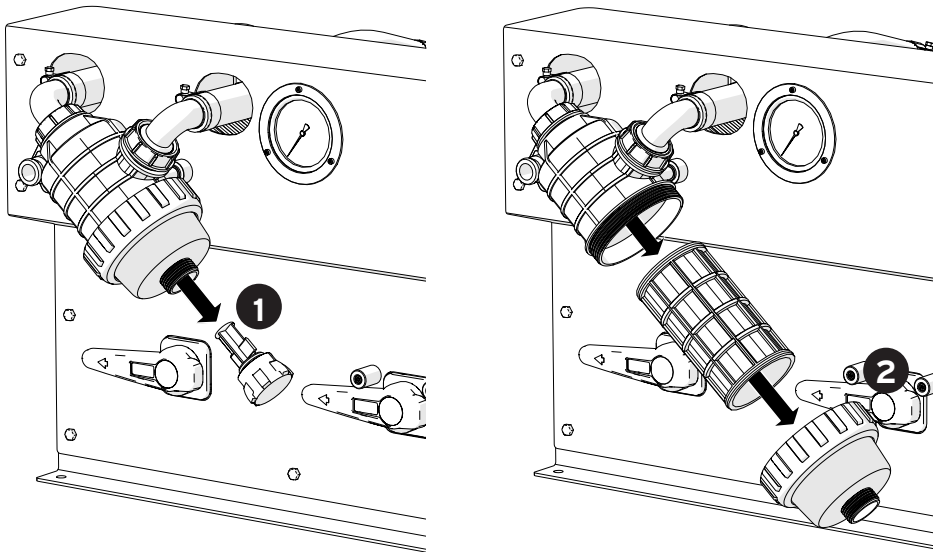

SHUTDOWN

1. Empty & Rinse Product Tank
2. Flush System
3. In freezing climates Flush System with Antifreeze
4. Remove Pump Manifold Drain Plug
5. Turn Function Selector Valve to PURGE TO GROUND

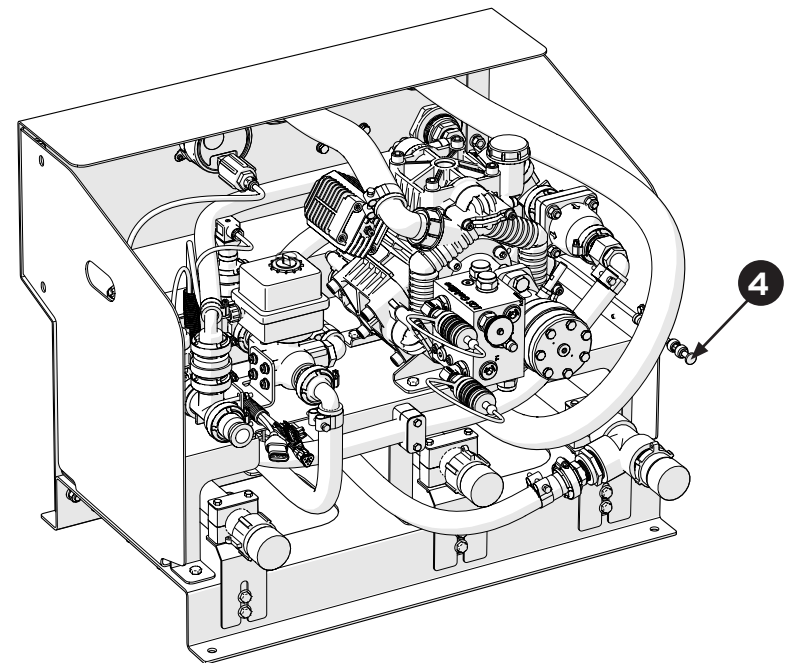

WARNING: Liquid will escape from the filter during this process. Ensure suitable protective gloves and clothing are worn when performing this task.



CAUTION: It is important when reassembling the suction filter that the screen bowl assembly be re-located correctly to the filter body. The pin location is crucial to operation of the filter. The pin activates a valve that will prevent the pump from sucking liquid if it is not seated correctly.

FILL PRODUCT TANK (applicable to LQS120 Combination Module)

1. Remove caps
2. Connect product transfer pump to fill port
3. Open vent/overflow port valve
4. Open fill port valve
5. Run transfer pump to fill product tank
6. Stop pump
7. Close valves
8. Disconnect transfer pump
9. Fit caps to ports

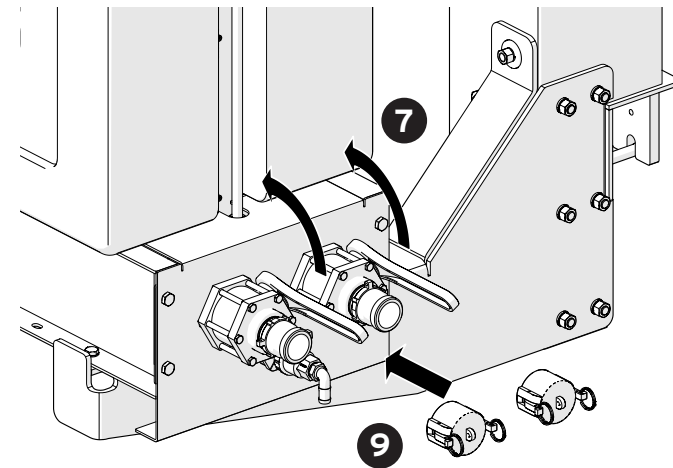
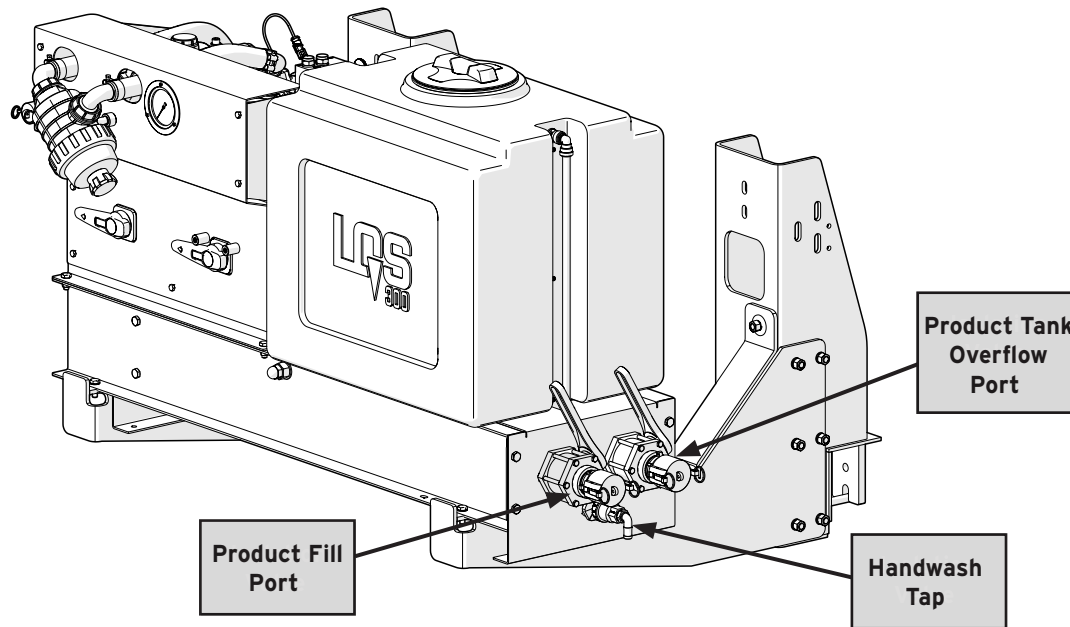
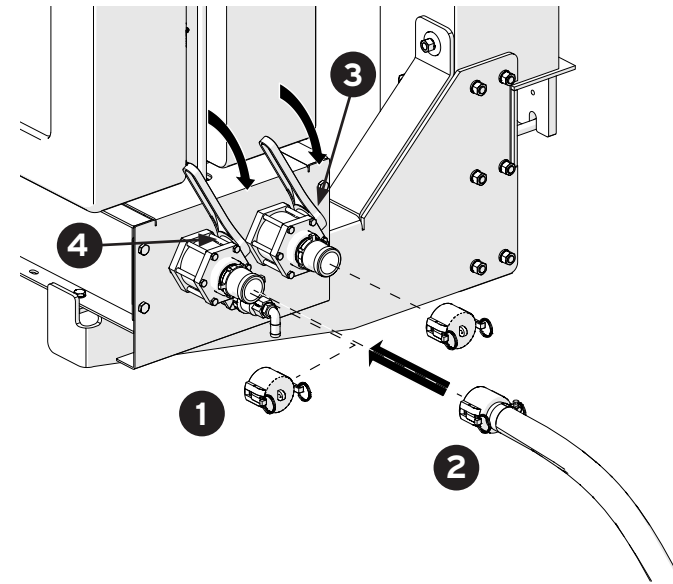

MODULE REAR ACCESS (applicable to LQS120 Combination Module)

The module has a sliding pivot mounting to allow easy access to the rear. To access the rear of the module:

1. Remove 3x bolts holding module in place as shown.
2. Use handle to slide module along and out.

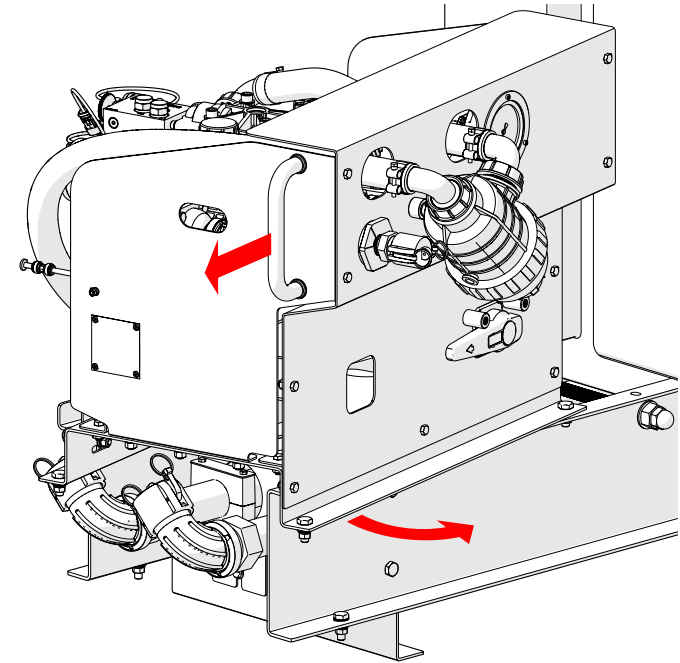
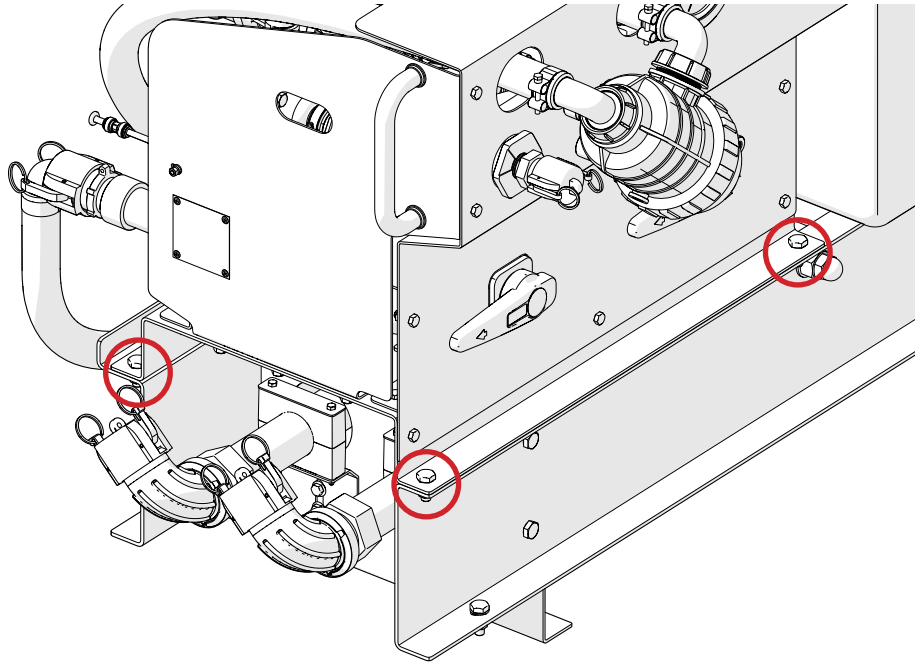

WARNING: ensure bolts are replaced when module is slid back into position

PUMP COMPONENTS

BE-62.0040.00.ADS
Duramax Diaphragm for 2136 pump



BE-62.9805.97.3
Set of 6 valves + O-rings for Bertolini 2136 pump

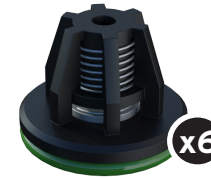

LQS-2136-EH PUMP
LQS Enhanced 2136 Pump



SELECTOR VALVES

AG-453426A77
2" 3-Way Ball Valve



AG-453055A55
1-1/4" 5-Way Ball Valve



SUCTION FILTER

AG-3162472
2" Short 32 mesh Suction Filter



AG-3162002.030
Short 2" Suction Filter 32 Mesh Screen



VALVE SET COMPONENTS

WK-531.0.13066880
Pressure Sensor

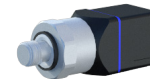

TJ-57-10100
TeeJet 801 Flowmeter



L03085
FSO Valve - 3-Way Flow 1" Valve



LL03003
Module Dual Scale Pressure Gauge Assembly (Kit includes fixings)



www.liquidusystems.com.au

